

## DESIGN AND THERMAL ANALYSIS OF DISC BRAKE

Gugulothu Shankar Naik<sup>1</sup>, Lanjapally Bhanu Sekhar<sup>2</sup>, Gadepaka Vikas<sup>3</sup>, Bhukya Saai<sup>4</sup>,  
G. Pavan<sup>5</sup>

<sup>1,2</sup>Associate Professor Mechanical Engineering Bomma Institute Of Technology And Science Khammam,  
Telangana, India.

<sup>3,4,5</sup>B. Tech Degree In Mechanical Engineering From The University Of JNTUH, Bomma Institute Of  
Technology Khammam, Telangana, India.

### ABSTRACT

The brake drum is a critical component that experiences high temperatures and develop thermal stresses during application of brakes. In addition, the application of shoe pressure gives rise to mechanical loads. So the analysis takes into account both the thermal stresses and mechanical stresses together. Since the analytical solution is not possible due to combination of loads and varying of contour of the brake drum, it is necessary to carry out finite element approach in order to evaluate the exact stress distribution and make sure that the stress values are well below the allowable limits.

In this paper Drum modelled by using cad tool creo-8, then it is imported into cae tool to analysis, in this case the model was checked by real time boundary conditions both static and thermal, with two materials by this we can find out deformation, stress, safety factor, and heat flux and total temperature distributions, from all the results we can find which material is most suitable for the object

**Key Words:** Brake, Thermal analysis, Rotor, Temperature distribution.

## 1. INTRODUCTION

A disc brake is a wheel brake that slows rotation of the wheel by the friction caused by pushing brake pads against a brake disc with a set of calipers. The brake disc (or rotor in American English) is usually made of cast iron, but may in some cases be made of composites such as reinforced carbon-carbon or ceramic matrix composites. This is connected to the wheel and/or the axle. To stop the wheel, friction material in the form of brake pads, mounted on a device called a brake caliper, is forced mechanically, hydraulically, pneumatically, or electromagnetically against both sides of the disc. Friction causes the disc and attached wheel to slow or stop. Brakes convert motion to heat, and if the brakes get too hot, they become less effective, a phenomenon known as brake fade. The development and use of disc-type brakes began in England in the 1890s. The first caliper-type automobile disc brake was patented by Frederick William Lanchester in his Birmingham, UK factory in 1902 and used successfully on Lanchester cars. Compared to drum brakes, disc brakes offer better stopping performance, because the disc is more readily cooled. As a consequence disc brakes are less prone to brake fade, and recover more quickly from immersion (wet brakes are less effective). Most drum brake designs have at least one leading shoe, which gives a servo-effect. By contrast, a disc brake has no self-servo effect and its braking force is always proportional to the pressure placed on the brake pad by the braking system via any brake servo, braking pedal or lever. This tends to give the driver better "feel" to avoid impending lockup. Drums are also prone to "bell mouthing", and trap worn lining material within the assembly, both causes of various braking problems

### 1. CAD

Computer aided design (cad) is defined as any activity that involves the effective use of the computer to create, modify, analyze, or document an engineering design. CAD is most commonly associated with the use of an interactive computer graphics system, referred to as cad system. The term CAD/CAM system is also used if it supports manufacturing as well as design applications

### Introduction to CREO

CREO is a suite of programs that are used in the design, analysis, and manufacturing of a virtually unlimited range of product CREO is a parametric, feature-based solid modeling system, "Feature based" means that you can create part and assembly by defining feature like pad, rib, slots, holes, rounds, and so on, instead of specifying low-level geometry like lines, arcs, and circle & features are specifying by setting values and attributes of element such as reference planes or surfaces direction of creation, pattern parameters, shape, dimensions and others.

"Parametric" means that the physical shape of the part or assembly is driven by the values assigned to the attributes (primarily dimensions) of its features. Parametric may define or modify a feature's dimensions or other attributes at any time.

For example, if your design intent is such that a hole is centered on a block, you can relate the dimensional location of the hole to the block dimensions using a numerical formula; if the block dimensions change, the centered hole position will be recomputed automatically. “**Solid Modeling**” means that the computer model to create it able to contain all the information that a real solid object would have. The most useful thing about the solid modeling is that it is impossible to create a computer model that is ambiguous or physically non-realizable.

There are six core CREO concepts. Those are:

- Solid Modeling
- Feature Based
- Parametric
- Parent / Child Relationships
- Associative
- Model Centric

#### **Capabilities and Benefits:**

1. Complete 3D modeling capabilities enable you to exceed quality and time to market goals.
2. Maximum production efficiency through automated generation of associative C tooling design, assembly instructions, and machine code.
3. Ability to simulate and analysis virtual prototype to improve production performance and optimized product design.
4. Ability to share digital product data seamlessly among all appropriate team members
5. Compatibility with myriad CAD tools-including associative data exchange and industry standard data formats.

#### **Features of CREO**

CREO is a one-stop for any manufacturing industry. It offers effective feature, incorporated for a wide variety of purpose. Some of the important features are as follows:

- Simple and powerful tool
- Parametric design
- Feature-based approach
- Parent child relationship
- Associative and model centric

#### **Simple and Powerful Tool**

CREO tools are used friendly. Although the execution of any operation using the tool can create a highly complex model

#### **Parametric Design**

CREO designs are parametric. The term “parametric” means that the design operations that are captured can be stored as they take place.

They can be used effectively in the future for modifying and editing the design. These types of modeling help in faster and easier modifications of design

#### **Feature-Based Approach**

Features are the basic building blocks required to create an object. CREO wildfire models are based on the series of feature. Each feature builds upon the previous feature, to create the model (only one single feature can be modified at a time).

Each feature may appear simple, individually, but collectively forms a complex part and assemblies.

The idea behind feature based modeling is that the designer construct on object, composed of individual feature that describe the manner in which the geometry supports the object, if its dimensions change. The first feature is called the base feature.

#### **Parent Child Relationship**

The parent child relationship is a powerful way to capture your design intent in a model. This relationship naturally occurs among features, during the modeling process. When you create a new feature, the existing feature that are referenced, become parent to the feature.

## 2. ASSOCIATIVE AND MODEL CENTRIC

CREO drawings are model centric. This means that CREO models that are represented in assembly or drawings are associative. Design of 3D mode in creo 9.0 parametric is as shown below.

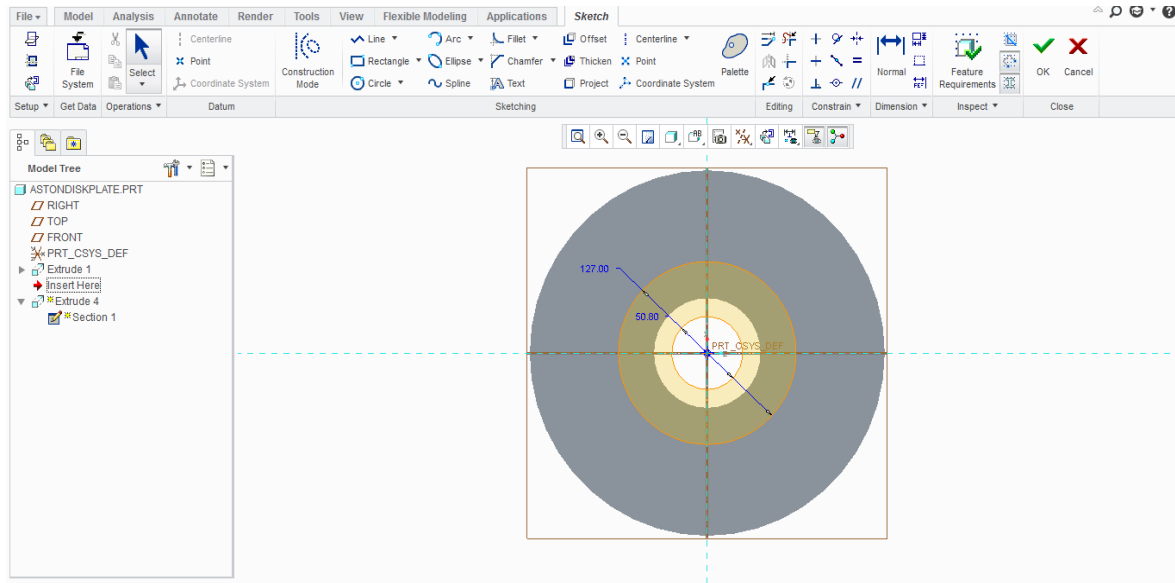

FIG.1

Disc brake initial MODEL

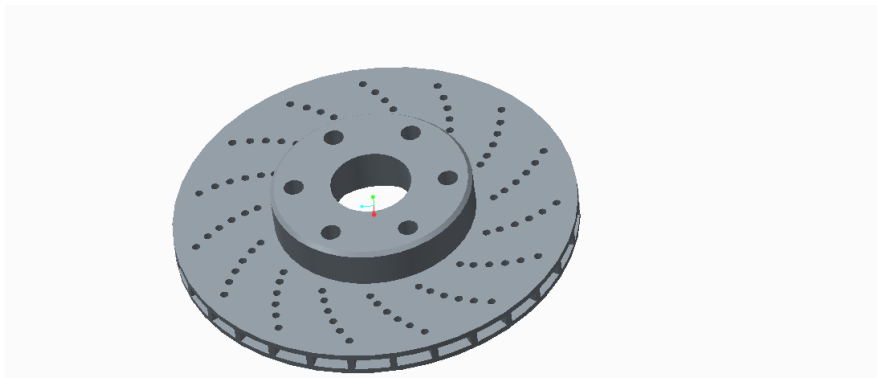

FIG.2

DISC BRAKE FINAL MODEL

## 3. ANALYSIS

ANSYS is an Engineering Simulation Software (computer aided Engineering). Its tools cover Thermal, Static, Dynamic, and Fatigue finite element analysis along with other tools all designed to help with the development of the product. The company was founded in 1970 by Dr. John A. Swanson as Swanson Analysis Systems, Inc. SASI. Its primary purpose was to develop and market finite element analysis software for structural physics that could simulate static (stationary), dynamic (moving) and heat transfer (thermal) problems. SASI developed its business in parallel with the growth in computer technology and engineering needs. The company grew by 10 percent to 20 percent each year, and in 1994 it was sold. The new owners took SASI's leading software, called ANSYS®, as their flagship product and designated ANSYS, Inc. as the new company name.

### 3.1. BENEFITS OF ANSYS

- The ANSYS advantage and benefits of using a modular simulation system in the design process are well documented. According to studies performed by the Aberdeen Group, best-in-class companies perform more simulations earlier. As a leader in virtual prototyping, ANSYS is unmatched in terms of functionality and power necessary to optimize components and systems.
- The ANSYS advantage is well-documented.
- ANSYS is a virtual prototyping and modular simulation system that is easy to use and extends to meet customer needs, making it a low-risk investment that can expand as value is demonstrated within a company. It is scalable to all levels of the organization, degrees of analysis complexity, and stages of product development.

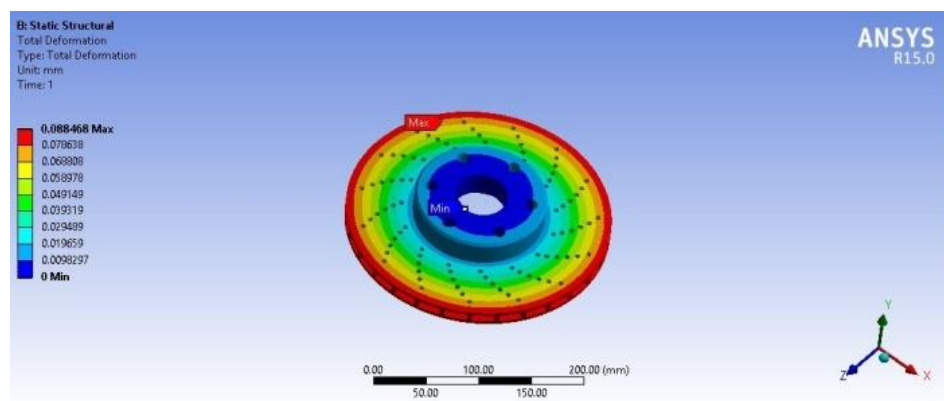
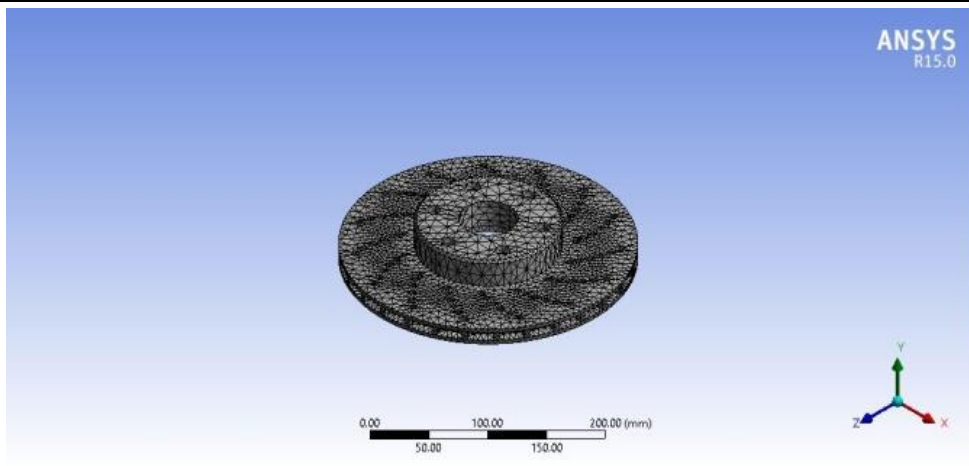

Figure 4: Deformation

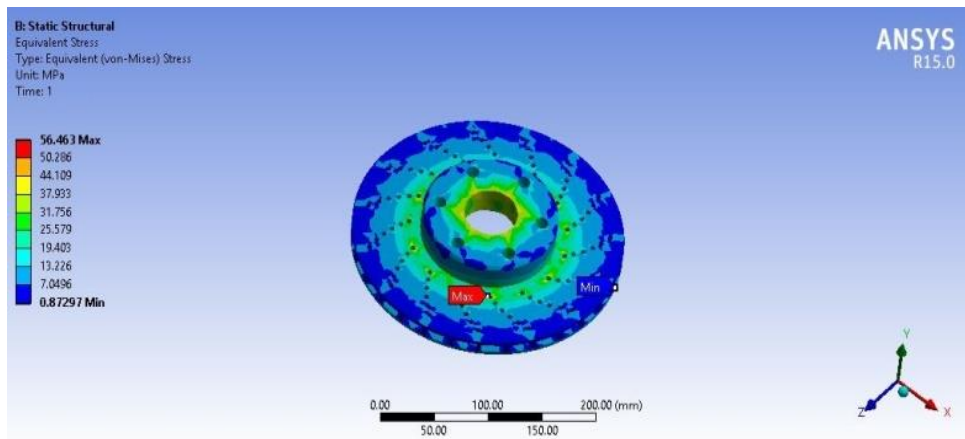

Figure 5: Stress

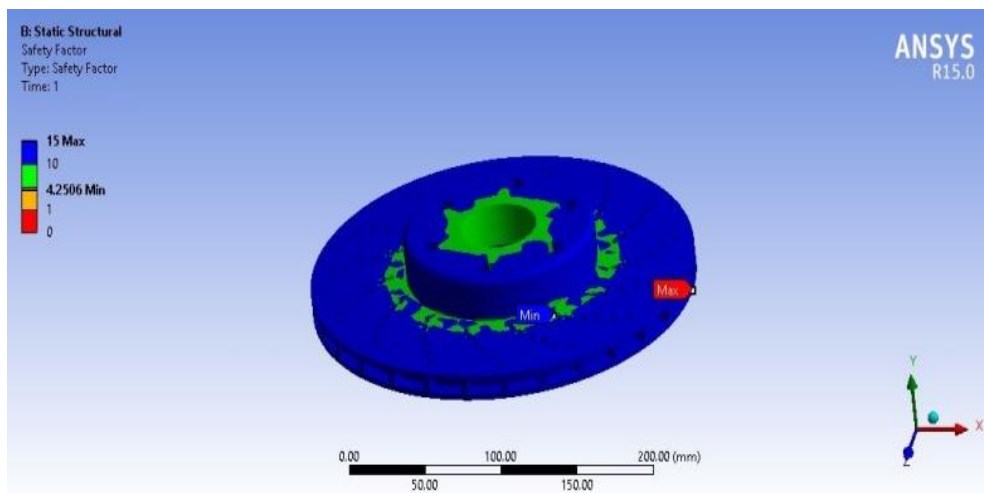

Fig. 6. Safety factor

Al-alloy

Deformation

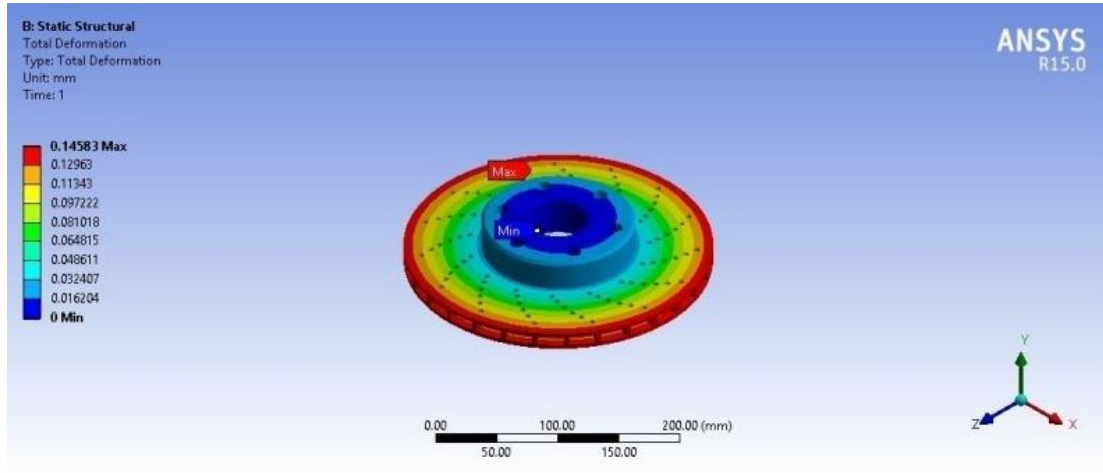
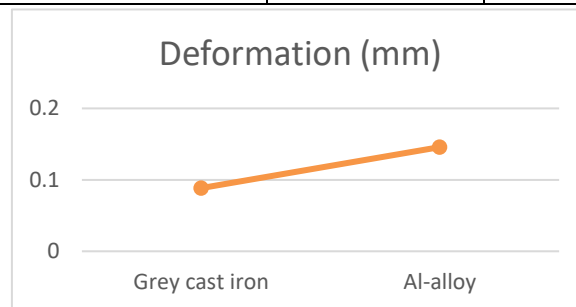

Fig. 3.4 Al- alloy Deformation

Table 1.1 Deformation

	Grey cast iron	Al-alloy
<b>Deformation (mm)</b>	0.088468	0.14583
<b>Stress (Mpa)</b>	56.463	55.041
<b>Safety factor</b>	4.2506	5.0871



Graphs.1

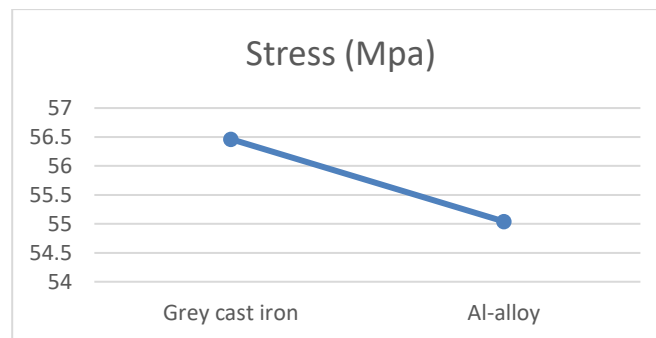

Graphs.2

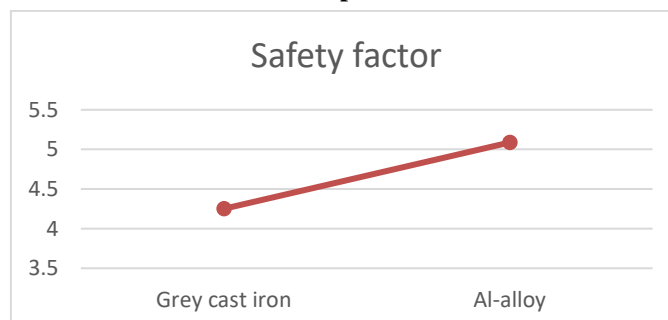

Graphs.3

#### 4. RESULTS

Existing material: Grey Cast Iron

Total temperature

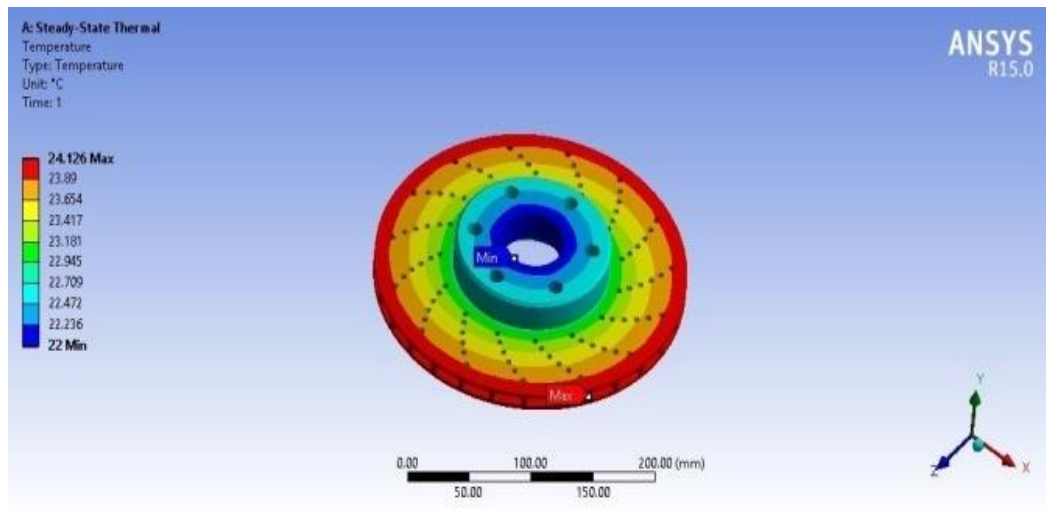

Fig. 4.3 Total Temperature

Total heat flux

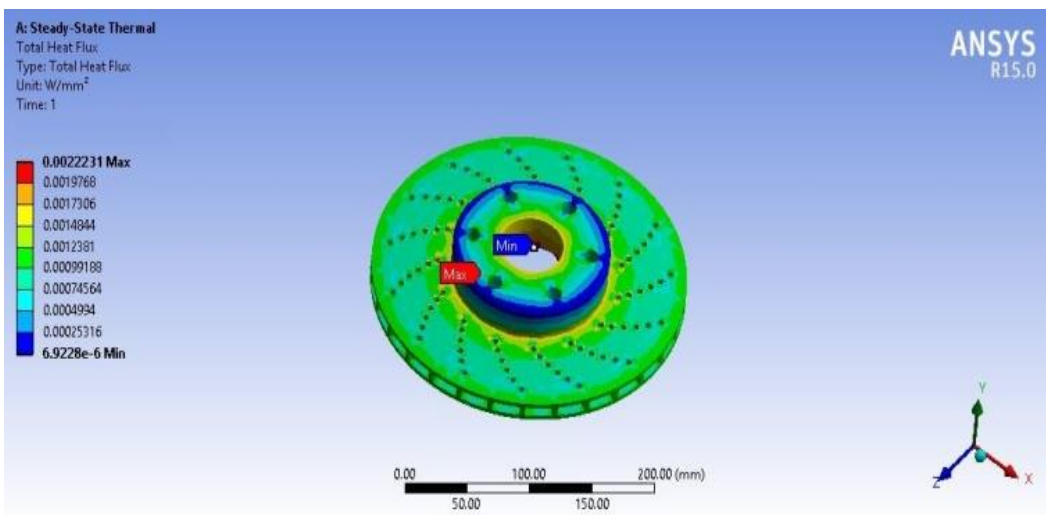

Fig. 4.4 Total Heat Flux

Heat flux in x-direction

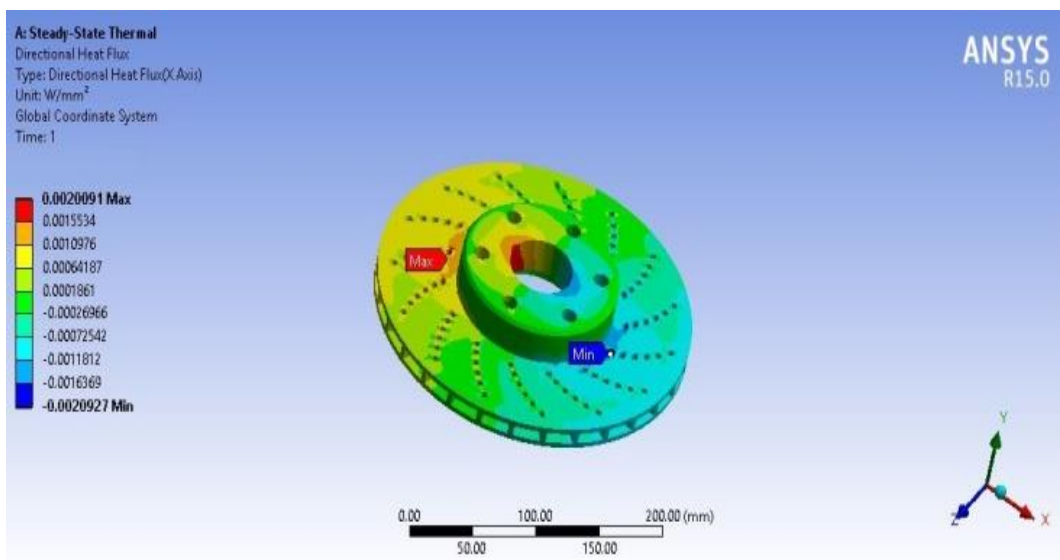
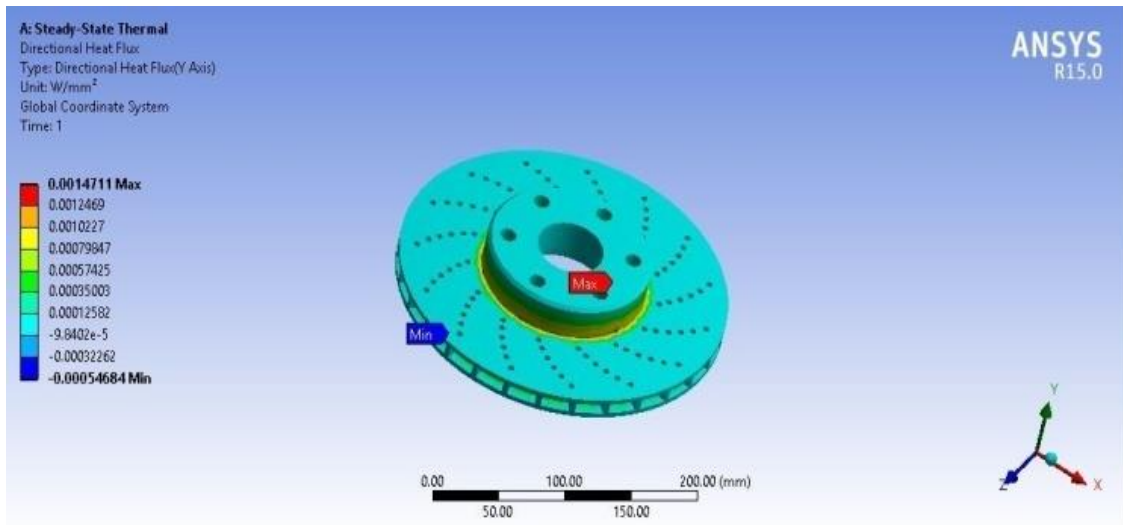

Fig. 4.5 Heat flux in x- direction

**Heat flux in y-direction**



**Fig. 4.6** Heat flux in y- direction

**Heat flux in z-direction**

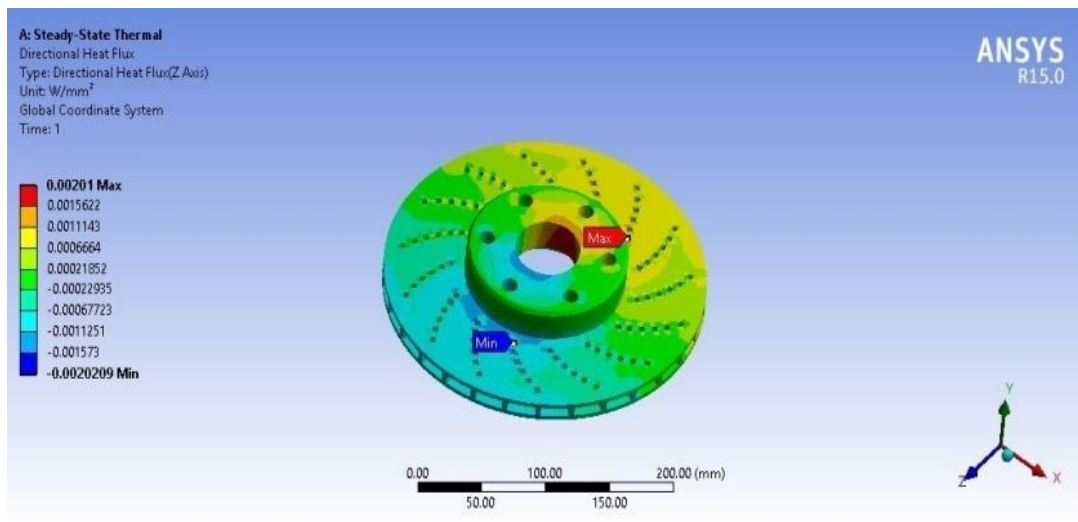

**Fig. 4.7** Heat flux in z- direction

**Existing material: al-alloy**

**Total temperature**

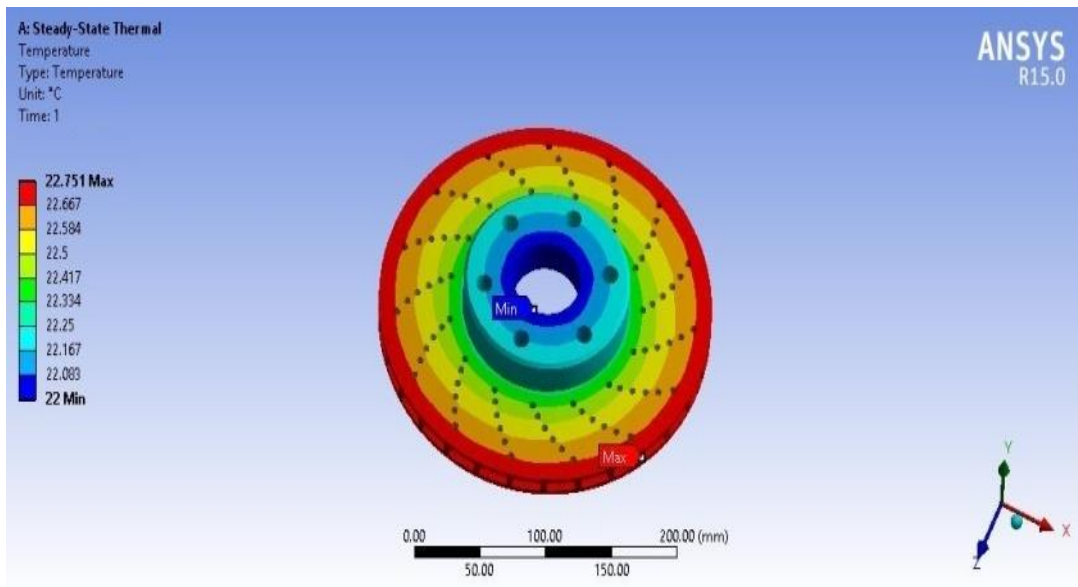

**Fig. 4.8** Existing material: al-alloy Total temperature

**Table 2.1** Total temperature

	<b>Grey cast iron</b>	<b>Al-alloy</b>
<b>Total temperature (*C)</b>	24.126	22.751
<b>Heat flux (w/mm^2)</b>	0.0022231	0.0022527
<b>Heat flux in x-direction (w/mm^2)</b>	0.0020091	0.0020359
<b>Heat flux in y-direction (w/mm^2)</b>	0.0014711	0.0014907
<b>Heat flux in z-direction (w/mm^2)</b>	0.00201	0.0020368

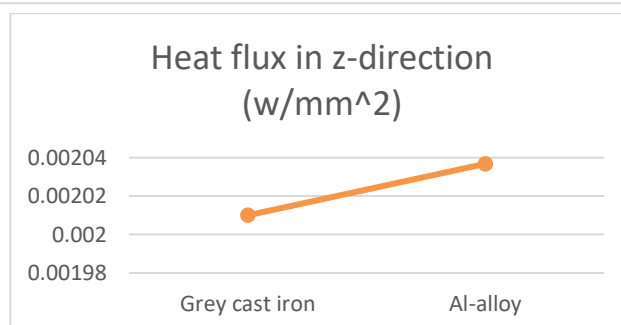
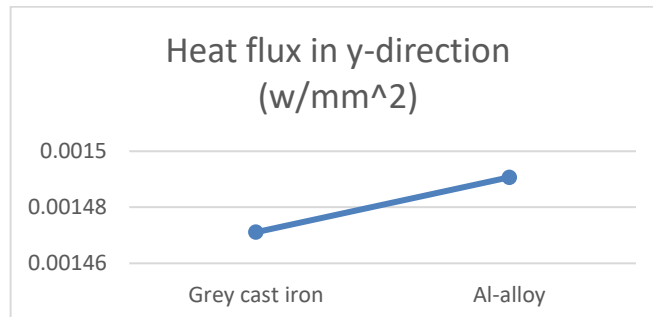
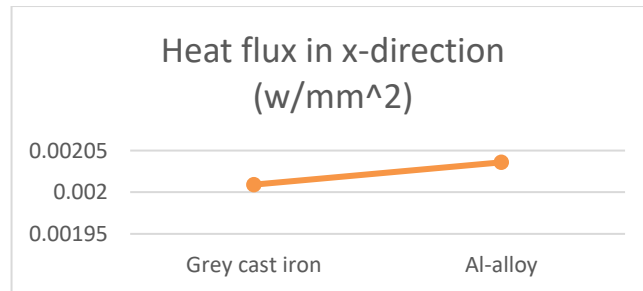
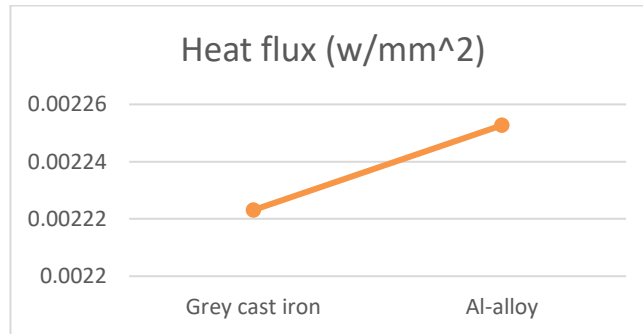
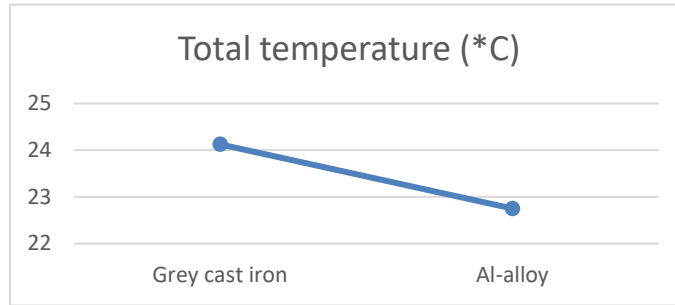



## 5. CONCLUSION

In our paper we have designed a break disc used in two wheeler and modeled in 3D modeling software CREO-8. and the we analyze the break disc with different materials like Aluminum And grey cast iron with help of fem In this Project we describes the stress distribution of the disc break by using FEA. The finite element analysis is performed by using computer aided design (CAD) software.

In this project we applied boundary condition as a 25000N weight and checked with existing material (grey cast iron) and also replace break disc material grey cast iron to al-alloy by this change we are getting less stress results for al-alloy and high safety factor also. By using al-alloy we can reduce our disc break weight nearly 35% of original model and this model also having less stress (55 MPa) and good safety factor 5.08. and the thermal heat flux also less (0.0022527 w/mm<sup>2</sup>) compare to grey cast iron, and also this material minimizes the total temperature of the object and this can increase the durability of the object

To get more accurate results here natural frequency results also calculated for each degrees of freedom it means total 6 natural frequency results calculated, from those values al-alloy has high frequency range compare to grey cast iron, it means al-alloy can withstand more vibration than grey cast iron, and resonance factor will reduce compare to grey cast iron, Finally thesis can be conclude with al-alloy material, this material perform better results in all 3 cases and it can increase the overall performance of the object

## 6. REFERENCES

- [1] MirzaGrebovic, "Investigation of the Effects on Braking Performance of Different Brake Rotor Designs".2013
- [2] Limpert, Rudolf "Brake Design and Safety", Society of Automotive Engineers. Inc, PA, USA, 2012
- [3] Warren Chan, "Analysis of Heat Dissipation in Mechanical Braking Systems". 2012
- [4] David A. Johnson, Bryan A. Sperandei, et.al., "Analysis of the Flow Through a Vented Automotive Brake Rotor, 2011
- [5] David Antanaitis and Anthony Rifici, "The Effect of Rotor Crossdrilling on Brake Performance".
- [6] SAE 2006-01-0691
- [7] Brake Design and Safety, 2nd Ed., Rudolf Limpert, 2010.
- [8] Dr. N.K. Giri, Automobile Mechanics, Khannapublishers, 2010.
- [9] James D. Halderman, Automotive Braking System, 2007.
- [10] Dr. Kirpal Singh, Automobile Engineering, Volume 1,
- [11] J. T. Kim and B. J. Baek, A numerical study of thermal performance in ventilated disk brake, Journal of the Korean Society of Tribologists & Lubrication Engineers, 17 (5) (2001) 358-364.
- [12] Y. Choi, J. W. Choi, H. M. Kim and Y. W. Seo, Thermal dissipation performance of the ventilated brake disc having helical grooved vent, Journal of the Korean Society of Precision Engineering, 21 (3) (2004) 117-123.
- [13] S. M. Kim, A study on thermal analysis in ventilated brake by FEM, Journal of the Korean Society of Machine Tool.
- [14] International Journal of Scientific & Engineering Research Volume 2 , Issue 8, August-2011.