

IOT-BASED SYSTEM FOR AUTOMATED ACCIDENT DETECTION - REVIEW

Abhishek A. Borale¹, Saurabh D. Sonawane², Vaishali A. Mhaske³, Urmika S. Dongre⁴,
Dr. A. N. Shaikh⁵

^{1,2,3,4,5}Department of Electronics and Telecommunication Engineering Shreeyash College of Engineering &
Technology, Aurangabad, Maharashtra, India.

ABSTRACT

The rapid rise of technology and infrastructure has made our lives easier. The high demand of automobiles has also increased the traffic hazards and road accidents. Life of the people is under high risk. The delay in reaching of the ambulance to the accident location and the traffic congestion in between accident location and hospital increases the chances of death of the victim. This proposed IOT based accident detection system helps to reduce the loss of life due to accidents and also reduces the time. To detect the accident there is humidity and temperature of car. With the help of accelerometer sensor signal, a severe accident due to an obstacle can be recognized. Microcontroller used, sends the alert notification through the mobile application rescue team. So, the emergency help team can immediately send notification.

Keywords-IoT, DHT-11, MQ-3 sensor, Blynk Cloud, Motor driver, motor, MQTT protocol, IoT, GSM, sensors, hospital, GPS, accident, Traffic Controlsystem, RFID

1. INTRODUCTION

The rapid advancement of technology has significantly transformed various sectors, including transportation. Despite these advancements, road traffic accidents remain a major global concern, leading to substantial loss of life and property. According to the World Health Organization, road traffic accidents are among the leading causes of death worldwide. In Saudi Arabia alone, more than 500,000 incidents are recorded annually, resulting in up to 17 fatalities per day. These alarming statistics highlight the urgent need for innovative solutions to enhance road safety and reduce accident-related fatalities.

One of the critical factors contributing to high mortality rates in road accidents is the delay in providing timely assistance to the injured. The traditional methods of accident detection and reporting often rely on bystanders or other drivers to notify emergency services, leading to significant delays. To address this challenge, the Internet of Things (IoT) offers a promising solution by enabling real-time monitoring and automatic detection of accidents. Accidents are a leading cause of death and injury worldwide, creating an urgent need for efficient and reliable detection systems. Traditional methods of accident detection, often reliant on human reporting, suffer from delays and inaccuracies, compromising the effectiveness of emergency response. Automated accident detection systems aim to overcome these limitations by providing real-time data and alerts to emergency services, enabling quicker and more coordinated interventions.

IoT-based accident detection systems typically comprise several key components: sensors (such as accelerometers, gyroscopes, and cameras) installed in vehicles and infrastructure; communication networks (like 4G/5G, LoRaWAN) to transmit data; and central processing units equipped with machine learning algorithms to analyze the data and determine the occurrence and severity of accidents. Additionally, these systems may integrate with existing traffic management and emergency response frameworks, enhancing overall efficiency.

This paper presents an IoT-based automatic vehicle accident detection system designed to improve response times and enhance the overall safety of road users. Main principle of the project is the detection and rescue management. The system is on and initialization. If vehicle is normal, no messages has been sent to rescue team. And the temperature level of the driver is monitored in all the time, if it reaches the threshold level then the action has been taken automatically. Whenever accident occurred, the MEMS sensor, tilt sensor and fire sensor detect the accident happened with vehicle. The controller gets the input from sensors and send the accident alert information to road side unit and then message is sent to the rescue team and also WIFI and GPS finds location of the vehicle and that also send to the rescue team. It will facilitate connectivity to the nearest hospital and provide medical help through IOT technology.

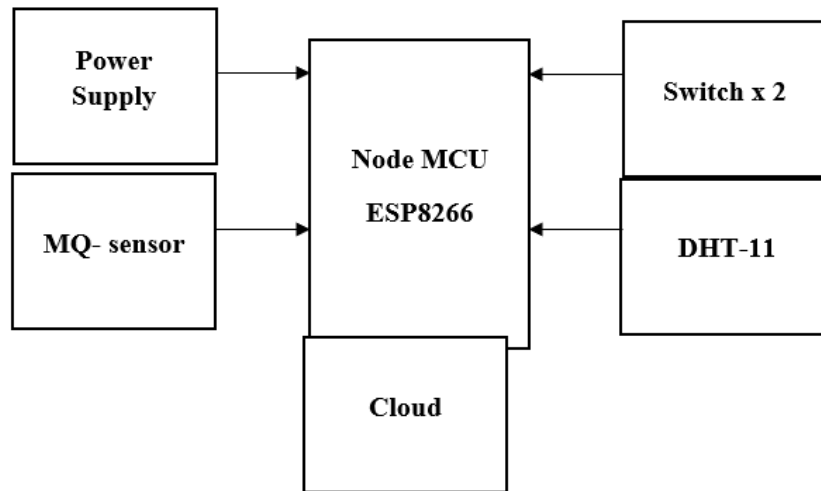

Fig.1: Block diagram

2. LITERATURE SURVEY

Enhancing road safety through vehicle communication is a promising concept that leverages the principles of wireless sensor networks (WSNs) and the Bluetooth protocol. This work explores the formation of mobile ad hoc networks (MANETs) by vehicles equipped with Bluetooth devices, enabling them to communicate and share sensor data in real time. By integrating sensor data from individual vehicles, a comprehensive understanding of traffic conditions can be achieved, potentially reducing accidents and improving overall traffic management. This study assesses the feasibility of using Bluetooth for inter-vehicle communication, focusing on coverage area and likelihood of detection for isotropic and non-isotropic sensors. Simulation results demonstrate that the collaboration between Bluetooth technology and sensor networks can significantly enhance road safety by providing timely alerts and insights into traffic scenarios. The findings suggest that this approach can be a viable strategy for preventing dangerous traffic situations and improving the safety of road traffic. [1]

Accident detection systems play a critical role in expediting the response time of emergency personnel, thereby reducing the number of fatalities resulting from auto accidents. Smartphones, equipped with sensors such as GPS and accelerometers, present an intriguing foundation for developing such systems. This publication presents three significant advancements in the study of smartphone-based accident detection systems. First, we address key challenges in traffic accident detection, such as minimizing false positives through the use of mobile context information and polling onboard sensors to detect significant accelerations accurately. Second, we outline the design of a prototype smartphone-based accident detection system and conduct an empirical analysis of its accident reconstruction capabilities and its resilience to false positives. Third, we explore how smartphone-based accident detection can mitigate overall traffic congestion and enhance the preparedness of emergency responders. The findings demonstrate that smartphone technology can be effectively utilized to develop reliable accident detection systems, ultimately improving road safety and emergency response efficiency. [2]

Saudi Arabia experiences more than 500,000 road incidents annually, with up to 17 fatalities per day, highlighting the critical issue of traffic accidents in the region. The high number of fatalities is largely attributed to the absence or delay in responding to injured individuals' needs for assistance. Motivated by this alarming statistic, we conducted extensive research to develop a solution aimed at reducing the impact of traffic accidents. This work presents a sensor-based microcontroller system that detects accidents immediately upon occurrence. By integrating a variety of sensors and modules with an Arduino microcontroller, the system can accurately identify and respond to accidents. Additionally, we have incorporated an Airbag sensor to enhance data precision and reliability. The proposed system aims to improve response times and thereby potentially reduce the number of fatalities resulting from road accidents. [3]

Traffic accidents are a significant concern worldwide, causing numerous fatalities and injuries each year. To address this issue, we propose an Accidents Detection and Prevention System designed to reduce traffic hazards using infrared (IR) sensors. This system aims to both detect accidents immediately upon occurrence and prevent potential accidents by monitoring and analyzing traffic conditions in real-time. By employing IR sensors, the system can accurately detect obstacles, sudden stops, and other hazardous conditions on the road. The integration of IR sensors with a microcontroller allows for the continuous monitoring of vehicle proximity and speed, facilitating timely alerts to

drivers and emergency services. The proposed system not only aims to enhance road safety by preventing accidents but also to improve the response time of emergency personnel, thereby reducing the severity of injuries and fatalities. This innovative approach leverages the capabilities of IR sensors to create a safer driving environment and mitigate traffic hazards effectively. [4]

The Internet of Things (IoT) has significantly enhanced road safety through automated accident detection systems. These systems use interconnected sensors and advanced algorithms to promptly identify and report vehicular accidents, reducing emergency response times and potentially saving lives. By providing real-time data and integrating with existing traffic management frameworks, IoT-based solutions improve detection accuracy and enable more efficient emergency interventions. [5]

Road traffic accidents claim numerous lives daily, primarily due to driver errors and delayed emergency responses. An effective system to detect accidents and swiftly communicate information to nearby emergency services is critical to saving lives. Various automatic accident detection systems have been proposed in research, leveraging technologies such as smartphones, GSM and GPS, vehicular ad-hoc networks, and mobile applications. This paper reviews these existing automatic road accident detection techniques and underscores the importance of implementing such systems in all vehicles. Additionally, it proposes a novel, cost-effective accident detection technique using ultrasonic sensors to enhance timely responses and improve survival rates for accident victims. [6]

Effective data collection and participatory sensing in vehicles can be significantly enhanced through direct communication between the driver's and owner's phones. This paper proposes a practical and optimized communication mechanism for direct phone-to-phone data transfer, utilizing Dual-Tone Multi-Frequency (DTMF) technology available on mobile phones to manage vehicle activities. By strategically enabling direct phone-to-phone communication, we can achieve cost-effective data sharing. Various sensors installed in the vehicle monitor its activities, and any detected abnormalities are promptly communicated to the vehicle owner via message. Using DTMF technology, the vehicle owner can remotely control and rectify these abnormalities, ensuring efficient management of vehicle issues from a distance. [7]

The increasing number of vehicles on the road worldwide has led to a significant rise in traffic-related hazards and road accidents. While technological advancements and infrastructure improvements have enhanced our daily lives, they have also contributed to this rise. These accidents result in substantial loss of life and property, often due to inadequate emergency response systems. Delayed communication with emergency medical services and the lack of immediate medical attention are primary contributors to accident fatalities, as extensive research has shown. This study aims to develop an accident detection system using an accelerometer and a vibration sensor to detect serious accidents during and after their occurrence. [8]

Road accidents rates are very high nowadays, especially two wheelers. Timely medical aid can help in saving lives. This system aims to alert the nearby medical center about the accident to provide immediate medical aid. The attached accelerometer in the vehicle senses the tilt of the vehicle and a heartbeat sensor on the user's body senses the abnormality of the heartbeat to understand the seriousness of the accident. Thus, the systems will make the decision and sends the information to the smartphone, connected to the accelerometer through gsm and gps modules. The Android application in the mobile phone will send text messages to the nearest medical center and friends. Application also shares the exact location of the accident and it can save time. [9]

The use of vehicles increases in the proportion of the population. Due to the traffic congestion, the accidents are also increasing day by day. This causes the loss of life due to the delay in the arrival of ambulances to the accident spot or from the accident spot to the hospital. So, it is necessary to take the accident victim to the hospital as soon as possible. Whenever an accident occurs, it has to be informed to the investigation unit. So, it is also beneficial if the intimation is reached to the enquiry section so that the time for the investigation can be minimized. [10]

Comparison of Existing System

Aspect	Bluetooth-Based MANETs [1]	Smartphone-Based Detection [2]	Sensor-Based Microcontroller [3]	IR Sensor-Based Detection [4]
Technology Used	Bluetooth, Wireless Sensor Networks (WSNs)	Smartphones with GPS and accelerometers	Various sensors (accelerometers, MEMS, tilt, fire), Arduino microcontroller	Infrared (IR) sensors, microcontroller
Primary	Real-time	Accident detection	Immediate accident	Accident detection and

Focus	communication between vehicles for traffic management and accident prevention	using smartphone sensors, reducing false positives	detection, improved emergency response	prevention through real-time traffic monitoring
Detection Method	Sensor data sharing between vehicles, forming mobile ad hoc networks (MANETs)	Polling onboard smartphone sensors, using mobile context information	Integrated sensors detect accidents, airbag sensor for enhanced precision	Monitoring vehicle proximity and speed with IR sensors
Coverage Area	Limited by Bluetooth range, effectiveness in localized areas	Broad, depends on smartphone distribution and network coverage	Wide, dependent on sensor and microcontroller deployment	Wide, dependent on IR sensor placement
Timeliness	Real-time alerts and traffic condition updates	Immediate detection and notification through smartphone network	Instantaneous detection upon accident occurrence	Immediate detection and alerting of hazardous conditions
Implementation Complexity	Medium - Requires installation of Bluetooth devices and sensors in vehicles	Low to Medium - Requires smartphone app and sensor integration	Medium - Involves multiple sensors and microcontroller programming	Medium - Involves IR sensor deployment and microcontroller integration
Limitations	Limited by Bluetooth range, dependency on vehicle-to-vehicle communication	Dependent on smartphone distribution, potential for privacy concerns	Requires proper sensor deployment, possible hardware costs	Dependent on IR sensor placement, may require extensive infrastructure setup
Year	2015	2019	2024	2022

Aspect	Internet of Things (IoT) [5]	Automatic Accident Detection Systems [6]	Direct Phone-to-Phone Communication [7]	Smartphone-Based Detection [8]	Immediate Medical Aid System [9]
Technology Used	Interconnected sensors, advanced algorithms	Various technologies including smartphones, GSM, GPS, vehicular ad-hoc networks, mobile applications	Dual-Tone Multi-Frequency (DTMF) technology, mobile phones	Smartphones with GPS and accelerometers	Accelerometer, heartbeat sensor, GSM, GPS
Primary Focus	Automated accident detection and reporting,	Automatic detection of road accidents,	Direct communication for vehicle	Smartphone-based accident detection,	Immediate alerting of nearby medical

	reducing emergency response times	timely alerts to emergency services	management and abnormality control	reducing false positives	centers for prompt medical aid
Detection Method	Sensor data integration and analysis, real-time reporting	Utilization of various technologies and onboard sensors	Direct phone-to-phone communication for data transfer	Smartphone sensor polling, mobile context information	Accelerometer for vehicle tilt, heartbeat sensor for abnormality detection
Coverage Area	Wide, dependent on sensor deployment and network connectivity	Wide, dependent on technology implementation and coverage	Dependent on phone signal strength and proximity	Broad, depends on smartphone distribution and network coverage	Near the accident location, dependent on GSM signal strength
Timeliness	Prompt identification and reporting of accidents, real-time data sharing	Swift detection and notification to emergency services	Immediate communication and control of vehicle abnormalities	Immediate detection and notification through smartphone network	Instant alerting of nearby medical centers upon accident occurrence
Implementation Complexity	Medium to High – Involves sensor deployment, algorithm development, and network integration	Medium – Requires integration of various technologies and sensor systems	Low to Medium – Utilizes existing phone capabilities and DTMF technology	Low to Medium – Requires smartphone app and sensor integration	Low to Medium – Involves accelerometer and sensor integration, mobile app development
Limitations	Dependency on sensor placement and network reliability	Potential for false positives, system integration challenges	Dependency on phone signal strength and compatibility	Dependent on smartphone distribution, privacy concerns	Dependency on GSM signal availability and medical center proximity
Year	2024	2024	2022	2021	2021

Advantages

- The system automatically detects accidents and immediately sends alerts to emergency services, eliminating delays caused by the need for bystander intervention. This rapid notification ensures that help arrives as quickly as possible.
- Continuous monitoring of the vehicle's condition, including the driver's temperature, ensures that any abnormalities are detected early. If the temperature reaches a dangerous threshold, the system can automatically initiate safety protocols.
- Automated detection and reporting reduce the potential for human error in accident reporting, ensuring that emergency services receive reliable and timely information.

Application

- Real time accident detection and reporting
- Faster emergency response
- Activating in vehicle safety features
- Improving traffic flow and reducing accident rates

Disadvantages

- High cost and restrictions of high-end vehicles
- Specific smartphone placement requirement

Future Scope

The proposed system deals with the detection of the accidents. But this can be extended by providing medication to the victims at the accident spot. By increasing the technology, we can also avoid accidents by providing alerts systems that can stop the vehicle to overcome the accidents.

3. CONCLUSION

In conclusion, the integration of IoT technologies in accident detection and response systems is a crucial step towards enhancing road safety. As technology continues to advance, further refinements and widespread adoption of such systems can lead to a significant reduction in the global toll of road traffic accidents, ultimately saving countless lives and mitigating the associated societal and economic impacts. The proposed system's ability to automatically detect accidents and immediately notify emergency services represents a substantial advancement in road safety technology. By minimizing delays in emergency response, this IoT-based solution has the potential to drastically reduce fatalities and improve outcomes for accident victims.

4. REFERENCES

- [1] A. Azhar, S. Rubab, M. M. Khan et al., "Detection and prediction of traffic accidents using deep learning techniques," *Cluster Computing*, vol. 26, no. 1, pp. 477–493, 2023.
- [2] Z. Xia, J. Gong, H. Yu, W. Ren, and J. Wang, "Research on urban traffic incident detection based on vehicle cameras," *Future Internet*, vol. 14, no. 8, p. 227, 2022.
- [3] Y. Sui, S. Zhou, Z. Ju, and H. Zhang, "A vision-based system design and implementation for accident detection and analysis via traffic surveillance video," *IEEE Canadian Journal of Electrical and Computer Engineering*, vol. 45, no. 2, pp. 171–181, 2022.
- [4] S. P. Shubham, M. Kumar, and S. Jain, "A survey on IoT based automatic road accident detection," in *Proceedings of the 2021 5th International Conference on Intelligent Computing and Control Systems (ICICCS)*, pp. 1–7, IEEE, Madurai, India, May 2021.
- [5] H. Lee, M. Kang, J. Song, and K. Hwang, "The detection of black ice accidents for preventative automated vehicles using convolutional neural networks," *Electronics*, vol. 9, no. 12, p. 2178, 2020.
- [6] B. K. Dar, M. A. Shah, S. U. Islam, C. Maple, S. Mussadiq, and S. Khan, "Delay-aware accident detection and response system using fog computing," *IEEE Access*, vol. 7, pp. 70975–70985, 2019.
- [7] D. Tian, C. Zhang, X. Duan, and X. Wang, "An automatic car accident detection method based on cooperative vehicle infrastructure systems," *IEEE Access*, vol. 7, pp. 127453–127463, 2019.
- [8] Al Wadhahi, N.T.S., Hussain, S.M., Yosof, K.M., Hussain, S.A. and Singh, A.V., 2018, August. "Accidents Detection and Prevention System to reduce Traffic Hazards using IR Sensors". In 2018 7th International Conference on Reliability, Infocom Technologies and Optimization (Trends and Future Directions)(ICRITO) (pp. 737-741). IEEE.
- [9] Z. A. Almusaylim, N. Zaman, and L. T. Jung, "Proposing a data privacy aware protocol for roadside accident video reporting service using 5G in Vehicular Cloud Networks Environment," in *Proceedings of the 2018 4th International conference on computer and information sciences (ICCOINS)*, pp. 1–5, IEEE, Kuala Lumpur, Malaysia, August 2018.
- [10] Kota, V.K., Mangali, N.K., Kanakurthi, T.K., Kumar, A.R. and Velayutham, T., 2017, March. "Automated accident detection and rescue system". In 2017 International Conference on Wireless Communications, Signal Processing and Networking (WiSPNET) (pp. 1437-1441). IEEE.
- [11] Liao, C., Shou, G., Liu, Y., Hu, Y. and Guo, Z., 2017, December. "Intelligent traffic accident detection system based on mobile edge computing". In 2017 3rd IEEE International Conference on Computer and Communications (ICCC) (pp. 2110-2115). IEEE
- [12] Liao, C., Shou, G., Liu, Y., Hu, Y. and Guo, Z., 2017, December. "Intelligent traffic accident detection system based on mobile edge computing". In 2017 3rd IEEE International Conference on Computer and Communications (ICCC) (pp. 2110-2115). IEEE.
- [13] Khalil, U., Javid, T. and Nasir, A., 2017, November. "Automatic road accident detection techniques": A brief survey. In 2017 International Symposium on Wireless Systems and Networks (ISWSN) (pp. 1-6). IEEE.
- [14] C K Gomathy and V Geetha. Article: Evaluation on Ethernet based Passive Optical Network Service Enhancement through Splitting of Architecture. *International Journal of Computer Applications* 138(2):14-17, March 2016. Published by Foundation of Computer Science (FCS), NY, USA, ISSN No: 0975-8887
- [15] C K Gomathy and V Geetha. Article: A Real Time Analysis of Service based using Mobile Phone Controlled Vehicle using DTMF for Accident Prevention. *International Journal of Computer Applications*

-
- 138(2):11-13, March 2016. Published by Foundation of Computer Science (FCS), NY, USA,ISSN No: 0975-8887
- [16] Ali, A. and Eid, M., 2015, May.” An automated system for accident detection”. In 2015 IEEE International Instrumentation and Measurement Technology Conference (I2MTC) Proceedings (pp. 1608-1612). IEEE.
- [17] R. Madli, S. Hebbar, P. Pattar, and V. Golla, “Automatic detection and notification of potholes and humps on roads to aid drivers,” IEEE Sensors Journal, vol. 15, no. 8, pp. 4313–4318, 2015.
- [18] Sanjana, K.R., Lavanya, S. and Jinila, Y.B., 2015, March.” An approach on automated rescue system with intelligent traffic lights for emergency services”. In 2015 International Conference on Innovations in Information, Embedded and Communication Systems (ICIIECS) (pp. 1-4). IEEE.
- [19] Anil, B.S., Vilas, K.A. and Jagtap, S.R., 2014, April.” Intelligent system for vehicular accident detection and notification”. In 2014 International Conference on Communication and Signal Processing (pp. 1238-1240). IEEE.
- [20] Meena, A., Iyer, S., Nimje, M., Joglekar, S., Jagtap, S. and Rahman, M., 2014, May.” Automatic Accident Detection and reporting framework for two wheelers”. In 2014 IEEEInternational Conference on Advanced Communications, Control and Computing Technologies (pp. 962-967). IEEE.