

## INTERNET OF THINGS BASED POWER THEFT DETECTION SYSTEM

B. Muthairulappan<sup>1</sup>, M. Muthukumar<sup>2</sup>

<sup>1</sup>Dept. of Electrical and Electronics Engineering, Sree Sowdambika College of Engineering Virudhunagar, Tamil Nadu India.

<sup>2</sup>Asst. Professor, Dept. of Electrical and Electronics Engineering, Sree Sowdambika College of Engineering, India.

### ABSTRACT

The technology of Internet of things for many real time problems is becoming most popular. In this research, real-time monitoring system for transformer as well as residential meter is proposed. The presented system provides existing and continuous access to energy consumption to the consumer by exploiting the advancement of IOT technology. This wireless technology is used to overcome the theft of electricity which can be done by using excess amount of power beyond the limit of meter as due to this access power revenue losses to the government as well as overloading and damage to the transformers occur. In this paper, main purpose is to detect the theft by detecting over loading at the transformer. Detection and control of power has been done by calculating the power consumed by the user at a given time with the help of meter. In this the transformer contain the theft detection unit which will notify to the main supplier side and the substation in the event of occurring the high power which will displayed on the webpage created by supplier. IOT operation can be performed by Wi-Fi device which sending transformer data to the web page. The IOT based concept is used so that Electricity board section continuously monitors the consumption of power on the particular area which can be displayed in LCD.

**Keywords :** Internet of things, detection, electricity theft, electricity meter, loads.

### 1. INTRODUCTION

Fraud done by electricity consumers so power utilities lose large amount of money each year. Electricity fraud can be define as a dishonest or illegal use of electricity equipment. It is difficult to distinguish between honest and dishonest customers. Realistically, electric utilities will never be able to eliminate fraud. To detect, prevent and reduce fraud it is possible to take measures [1]. India experienced massive power shortages on the successive days in July 2012. The second is the largest blackout ever recorded, affecting nearly 620 million people in 22 out of 29 of India's states. Lack of available capacity, weak infrastructure and poor electricity supply governance are recognized as the main causes for such a generalized failure. With regard to governance, it has been suggested that more than 20% of the total electricity generated in India is stolen [2]. For investigations by electric utility companies technical losses in generation, transmission and distribution networks, and the overall performance of power networks are undertaken [3]–[6]. However, power theft problem in developing and under developed countries is common. Different non technical and technical ways will be proposed regarding power theft in meter. In [8], a new approach towards Nontechnical loss (NTL) detection in power utilities in order to detect and identify load consumption patterns of fraud customers using artificial intelligence based technique and pattern classification technique. In this system customer committing fraud activities before the two year period will not be detected by the FDM. Although, this method reduce theft but require large man power. Due to dishonesty of staffs this methods fails. Some of the technical ways to detect stealing are done in [9], authors developed a paper on real time system in which transmission and receiving of data is done by wireless technique using PLC. This will provide an additional facility of wireless meter reading with the same technique and in same cost. Due to this it will protect distribution network from power theft done by tapping, meter tampering etc. The proposed system is an automated system of theft detection which found to be little bit complex. A similar work is done in [10] but here zigbee technology is used for theft detection and this system have the advantages that it can also be used to detect the theft of the gas, fuel and oil simply by changing the measurement meter used in this system. In [13], the real-time monitoring system for residential energy meter is done using IOT technology. In this the collected data is found due to the pattern of consumption as well as faultiness present in the existing system is obtained. The theft occurred due to using the excess amount of power beyond the limit of meter is done in [14]. The project finds the solution for monitoring the power theft happening in and around a particular locality is done in [15]. In this paper, we have proposed an attempt to resolve electricity theft problem. The research detects the pilferage by detecting over loading at the transformer. A relay circuit is employed to shut down the power supply from the respective transformer in case of overloading. Information regarding the load consumption is send wirelessly using IOT technology and the status of meter will be showing on the LCD. Another major advantage of this method is that it will provide security that the whole system is accessible by the authorized person.

## 2. PROPOSED METHODOLOGY

The architecture and working of the proposed system is explained in this section. It also describes the meter setup and the hardware components used in this research.

### 2.1 Hardware module-

In the proposed system the power utility maintains a server and each consumer are provided a meter. Local network and IOT ESP8266 module are used by the server and the meter to communicate with each other. Fig. 1 shows an overview of the proposed power theft detection system. The electricity meter consists of a microcontroller (ATmega 328), current sensor, LCD display, relay, keypad and IOT ESP8266. In this the current sensing sensor sense the amount of current receives to the meter in the form of power as power directly proportional to the current. The predefined data is stored in Electrical erasable read only memory (EEPROM) of AT89C52 microcontroller which allows to store data that and can be erasable and reprogrammable so the data which is stored in the memory is remain present till the data will be overwrite. When the supply is given after removing the supply it will take the previous set value which is set by the supplier. The reading of meter is displayed on LCD. Relay is used as a switch. The meter reading is transfer to the webpage of electricity board section using Node MUC IOT ESP8266. If amount of power used by meter is beyond the limit then the notification regarding theft is displayed on the webpage of electricity board section. This system allows the supplier to disconnect the connection from a distant server in case the sector utilizing high power. This method eliminates the need of human power during disconnection and reconnection of the load.

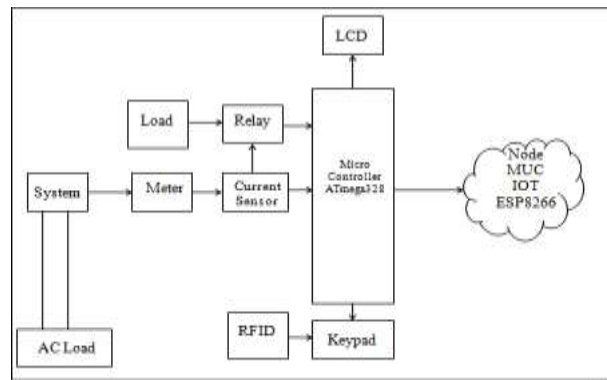

Figure 1. Proposed Block Diagram

Another major advantage of this method is that it will provide security that the whole system is accessible by the authorized person. The local host html webpage is created by the Electricity board section which is based on the given condition it shows the consumption of power in a given sector in units form as well as showing the power is in limit or beyond the limit by using IOT ESP8266 Wi-Fi module which sends the information wirelessly.

### 2.2 Process Flow

The process flow has clearly defining the actual design steps of detection of theft. Here, once the device is power ON all components will be initialized. The system will check the connectivity interface is in proper working condition. If the connectivity interface is working properly, the system constantly checks if the power theft in the meter occurred or not and the meter reading will be displayed on the webpage. As the power theft occurred, the sensor will send a signal to the processor which in turn triggers the connectivity interface to send a message to the web that the meter has been using a high amount of power. The notification is displayed on the webpage if the high amount of power is consumed then the supplier disconnects the load from the distribution network of the particular sector.

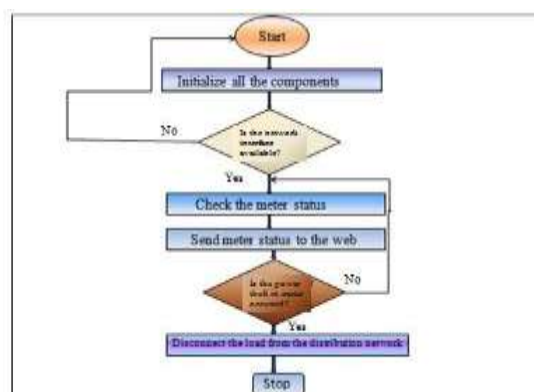

Figure 2. Process Flow

### 2.2.1 Hardware Setup

The entire meter setup at the transformer side as well as to the consumer side is shown in Figure 3.

In this the current sensor output pins are connected to the loads. The LCD source VDD pin and VSS pin are connected to the source and ground pin of ATmega328. For displaying the data the D0-D7 pins of LCD are connected to same pin of the microcontroller. The meter status is checked using Proteus software by in different conditions. In this on increasing the load power increases.



Figure 3. Developed experimental Setup

### Software flow of meter reading

The software flow of meter reading is shown in Fig.4. In meter reading flow, firstly ESP8266 and sensor are connected to the microcontroller. After that program begins formatted the network, if the network is formatted successfully, and network coordination connect to computer, we can find the physical address of network coordination, network ID and channel number by software. Then network coordination is in operation state. Then the data is connected to WI-FI and monitoring parameter is stored in cloud which can be displayed in units form.

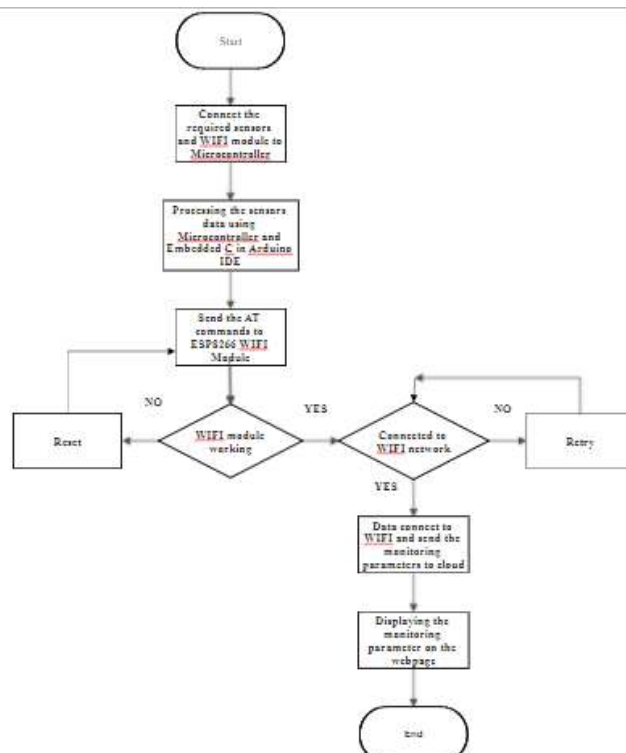

Figure 3. Software flow of meter reading

### 3. RESULT

The live readings of the meter are display in the webpage created by the electricity board section along with the power consumption of meter and the status of meter are displayed on LCD as shown in fig.4. If the power theft is occurred then the notification regarding power theft are displayed on the webpage as well as on LCD as shown in fig.5. This system now cannot be reset by the consumer i.e. it now needs a person from the authorized agency to reset the whole of the system.



Figure 4. Meter status at normal condition



Figure 5. Meter status at Overload condition

### 4. CONCLUSION

This wireless IOT based technique is much useful to detect the stealing of the electricity worldwide. To control the revenue losses the authorized officials needs to detect the theft of the electricity it means the theft of the power beyond the limit is the most effective one over the whole world comparing to the other techniques used to steal the electricity i.e. the unauthorized consumption of the electricity. It provide safety as the limit of the transformer will change by the authorized person of electricity board section along with the supply cut by this system can only be reset by them therefore this system helps to reduce the manual error and provide an excellent way to detect the bypassing of the energy meter. Hence further more and more improvements will be done to make the system much more efficient and excellent also for the long haul. The analysis between consumption of power is performed using Labview.

### ACKNOWLEDGMENTS

I would like to give my sincere gratitude to my guide Mrs. Suchitra Pandey and co-guide Mr. D. Reynolds for their guidance and support.

### 5. REFERENCES

- [1] R. Jiang, H. Tagaris, A. Lachs, and M. Jeffrey, "Wavelet based feature extraction and multiple classifiers for Electricity fraud detection", in Proc. IEEE Power Eng. Soc. Transmission and Distribution Conf. Exhibit. Asia Pacific, vol. 3, (2002) pp. 2251–2256.
- [2] A Rubino, "Energy Transmission and Distribution Power theft in India," , NatureEnergy Policy 93 , 127– 136 Article number: 16044, (2016).
- [3] C.R.Paul,," System loss in a metropolitan utility network", Power Eng. J., vol. 1, no. 5, (1987) ,pp. 305– 307.
- [4] N.Tobin and N.Sheil,," Managing to Reduce Power Transmission System Losses, in Transmission Performance.Dublin", Ireland: Publ. Electricity Supply Board Int.(1987).

- [5] R. L. Sellick and C. T. Gaunt, "Load Data Preparation for Losses estimation", in Proc.7th Southern African Universities Power Engineering Conf. , Stellenbosch, South Africa, vol. 7, (1998), pp. 117–120.
- [6] I. E. Davidson, A. Odubiyi, M. O. Kachienga, and B. Manhire, "Technical loss computation and economic dispatch model in T&D systems in a deregulated ESP", Power Eng. J., vol. 16, no. 2, (2002),pp. 55–60.
- [7] Dimitrios Georgakopoulos, Prem Prakash Jayaraman ,” Internet of things: from internet scale sensing to smart services”, in Springer-Verlag Wien, ISSN: 0010-485X (2016).
- [8] Jawad Nagi, Keem Siah Yap, Sieh Kiong Tiong, Syed Khaleel Ahmed and Malik Mohamad, "Nontechnical Loss Detection for Metered Customers in Power Utility Using Support Vector Machines", IEEE Transactions on power delivery, VOL. 25, NO. 2, Print ISSN: 0885-8977, Electronic ISSN: 1937-4208, (2010).
- [9] U.Grasselli, A. Prudenzi, "Utilization of a PLC in power system protection applications", IEEE Applications of Industrial Electronics Systems, (1990).
- [10] Raksha Kala, "Energy Conservation and Monitoring System for Smart City using Internet of Things", SSRG International Journal of Computer Science and Engineering (SSRG-IJCSE), volume 3 Issue 8, (2016).
- [11] G. L. Prashanthi, K. V. Prasad, "Wireless power meter monitoring with power theft detection and intimation system using GSM and Zigbee networks", IOSR Journal of Electronics and Communication Engineering (IOSR-JECE) e-ISSN: 2278-2834,p- ISSN: 2278-8735.Volume 9, Issue 6, (2014), PP 04-08.
- [12] Chun-Hao Lo and Nirwan Ansari, "CONSUMER: A novel hybrid intrusion detection system for distribution networks in Smart Grid", IEEE Transactions on Emerging Topics in Computing Volume: 1, Issue: 1, Electronic ISSN: 2168-6750, (2013).
- [13] Karthikeya S, Bhuvanewari P.T.V,"IoT Based Real-Time Residential Energy Meter Monitoring System",IEEE Trends in Industrial Measurement and Automation (TIMA),Electronic ISBN: 978-1-5090- 3001-9 ISBN: 978-1-5090-3002-6, (2017).
- [14] Harsha Khandel , Suchitra Pandey and D. Reynolds, "A Review on IOT Based Power Theft Detection and Control Systems", International Journal of Innovative Research in Electrical, Electronics, Instrumentation and Control Engineering, Vol. 5, Issue 9, ISSN (Online) 2321 – 2004 ISSN (Print) 2321 – 5526 , (2017).
- [15] Nabil Mohammad, Anomadarshi Barua and Muhammad Abdullah Arafat, "A Smart Prepaid Energy Metering System to Control Electricity Theft",IEEE International Conference on Power, Energy and Control (ICPEC),Electronic ISBN: 978-1-4673-6030-2 Print ISBN: 978-1-4673-6027-2, (2013).
- [16] Chun-Hao Lo and Nirwan Ansari, "CONSUMER: A novel hybrid intrusion detection system for distribution networks in Smart Grid", IEEE Transactions on Emerging Topics in Computing Volume: 1, Issue: 1, Electronic ISSN: 2168-6750, (2013).