

NEURAL NETWORK BASED MPPT CONTROLLER WITH BOOST CONVERTER FOR FUEL CELL BASED ELECTRIC VEHICLE

Aakanksha Changdeo Bhaisare¹, Prof. Diksha khare²

^{1,2}Department of Electrical Engineering Guru Nanak Institute of Technology (GNIT) Nagpur, India

ABSTRACT

Due to the strict guidelines on carbon emissions and the gas financial system, fuel cell electric motors (FCEV) motors are becoming an increasing number of famous inside the car enterprise. This paper offers the neural network most electricity point monitoring (MPPT) controller of the 1.26 kw proton change membrane gas mobile (PEMFC), which affords electric car powertrain the usage of dc-dc strength converters. The proposed neural network controls the MPPT radial basis feature community (RBFN) the usage of the PEMFC maximum power point (MPP) tracking algorithm. High frequency switching and high dc-dc converted energy are vital for FCEV continuity. For maximum energy benefit, a 3-phase power deliver interleaved boost converter (IBC) is also designed for FCEV systems. The interleaving technique reduces the contemporary enter stress and electrical strain within the semiconductor electric tool. FCEV gadget overall performance analysis with RBFN based totally MPPT manage in comparison to fuzzy Logic controllers (FLC) on the MATLAB / Simulink platform.

Keywords: Fuel cell electric vehicle, high voltage gain IBC, PEMFC, MPPT, RBFN etc.

1. INTRODUCTION

Due to The Environmental Pollution and Finite Reserves of Fossil Fuels, Automobile Industries Are Showing More Interest In electric cell Electric Vehicles (FCEV). The Rapid Advancements in Power Electronics And electric cell Technologies Have Empowered the numerous Development in FCEV. Fuel Cells Have the advantages of fresh Energy Production, High Reliability, High Performance and Low Sound. counting on the kind Of Electrolyte Substance Cells Are Categorized Into differing types like Proton Exchange Membrane Fuel Cell (PEMFC), Alkaline cell (AFC), oxyacid electric cell (PAFC), Solid oxide cell (SOFC) and Molten Carbonate electric cell (MCFC). within the midst of all of this, PEMFCS controls the automotive industry because of its cold and fast start.

▪ FUEL CELLS

Thanks to Environmental Pollution and also the End of Natural Oil Depot, the Automotive Industry Shows More Interest in Electric Vehicles.

Fuel Cells Have the advantages of unpolluted Power Generation, High Reliability, High Efficiency and Low Noise.

PEMFCs Are Dominating the car Industry due to Their Low Operating Temperature and also the fast Start-up.

▪ MPPT

MPPT Algorithms, P&O is easy, popular and straightforward to use. P&O And Incremental Conduction Methods Produces Oscillations at Steady State which is able to Reduce Efficiency of Cell System.

To overcome this problem, symbolic logic controllers and neural network algorithms were introduced to detect MPPT with increased efficiency and accuracy.

Radial Basis Function Network (RBFN) MPPT Base Control Suggested PEMFC MPPT Tracking.

A high voltage gains three-phase non-isolated interleaved boost converter (IBC) for electric cell applications to achieve low switching stress and high voltage gain. The fraudulent measure measures the reliability of the cell and provides greater power. The output voltage of the proposed converter is given to the electrical motor through an inverter for propulsion of the vehicle. the electrical motor plays a vital role in FCEVs. An adequate motor considerably reduces the price and size of the cell.

2. Objectives

The primary objectives of this study are often summarized as follows:

- 1) To study the Neural Network Based MPPT Controller.
- 2) To understand the Boost Converter concept deeply.
- 3) To study MPPT topology, modulation strategy and operating principles Widely.
- 4) To study simulation validations of the proposed system.

3. ELECTRIC VEHICLE CHARGING IN FUEL CELL APPLICATION

Like every electric automobile, FUEL cell electric cars (FCEVs) use electricity to electricity electric powered vehicles. Unlike other electric vehicles, FCEVs generate electricity using a hydrogen-powered fuel cell rather than drawing energy from a battery. During the vehicle design process, the vehicle manufacturer defines the power of the vehicle by the size of the electric motor

(s) that receive the appropriate amount of electrical power from the fuel cell and battery combination. Although vehicle manufacturers were able to design an FCEV with plug-in capabilities to charge the battery, most FCVVs today use batteries to recover braking power, providing additional power during low acceleration events, and lubricants with the option of deactivating the energy delivered from the fuel cell. Or turn off the fuel cell during low power requirements. The amount of energy stored in the vessel is determined by the size of the hydrogen fuel tank. This is different from an all-electric vehicle where both available power and power are closely related to battery size. Learn more about fuel cell electric vehicles.

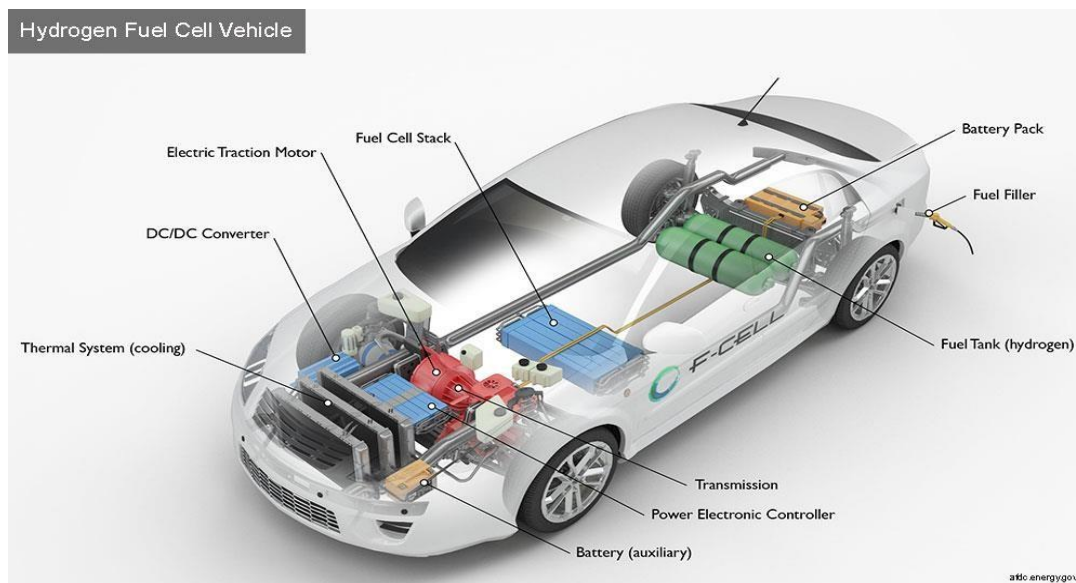

Fig1. Fuel Cell Vehicle

FCEVs use a propulsion device much like electric cars, where the energy stored in the shape of hydrogen is transformed into strength by means of the fuel cellular. Unlike traditional internal combustion engine vehicles, these vehicles do not emit harmful tail pipe. Other benefits include increasing U.S. energy security and strengthening the economy. The FCEV vehicle is filled with pure hydrogen gas stored in a tank. Like traditional internal combustion engine vehicles, they can be refueled in less than 4 minutes and have a range of over 300 miles. FCEV is ready with other advanced technology to growth performance including regenerative braking structures, which seize the strength lost at some point of braking and keep it inside the battery. Major automobile manufacturers are offering non-limited FCEVs in some markets, which will help develop infrastructure.

4. LITERATURE REVIEW

- Moe Moe Lwin and Htin Lin “Neural Network Based High-Performance Double Boost DC-DC Converter in Using Renewable Energy System” *International Journal of Science, Engineering and Technology Research (IJSETR)* Volume 7, Issue 5, May 2018

Different types of DC-DC converter are used on various electronic and multi-use devices for many years. But a standard converter cannot pay for high voltage values and high current applications. Many investigators have tried to meet the requirements. In this paper, a two-step reinforcement DC-DC converter is used for the renewable energy system. Finding a way to control rather than the best performance under any circumstances is always required. The Voltage mode control process is used to achieve a high output voltage with the help of a high-level controller. The main purpose of this paper is to study the Neural Network Controller (NNC) under the response of the various parameters of the proposed converter using MATLAB / Simulink Software.

- N. Sudhakar “High Step-Up Boost Converter with Neural Network Based MPPT Controller for a PEMFC Power Source Used in Vehicular Applications” *International Journal of Emerging Electric Power Systems*, 19(5), 20180015, 2018

This paper deals with the high mechanical replacement and the high-power conversion of DC-DC are required in

electric vehicles. In this paper, a new advanced step-by-step converter (HSBC) is designed for high-performance electronic data processing (FCEV) applications. The designed converter offers the best gas power advantage compared to a conventional converter amplifier and reduces the current input and pressure pressures on the semiconductor candy power. Additionally, a neural-based Maximum Point Tracking (MPPT) controller was developed for the 1.26 kW protonexchange membrane fuel cell (PEMFC). Network radical base function (RBFN) algorithm is used in neural network control to extract high energy from PEMFC in different temperature conditions. The performance analysis of the designed MPPT control is analysed and compared with the controlled logic control (FLC) in the MATLAB / Simulink area.

5. PROBLEM IDENTIFICATION

Existing configuration:

The wheelwork Architecture of FCEV Is Shown in Fig 2. A Stack of PEMFC Produces an Unregulated Low Dc Output Voltage.

Boost or step-Up DC-DC Converter Is Required to spice up and Regulate the PEMFC Output Voltage.

A quadratic boost converter composed of two boost converters is proposed to understand high voltage gain. But, using of two boost converters may reduce the efficiency of the system. A 2- phase flexible converter amplified between DC-DC protective is typically recommended. However, this topology suffers from poor reliability and fewer efficiency.

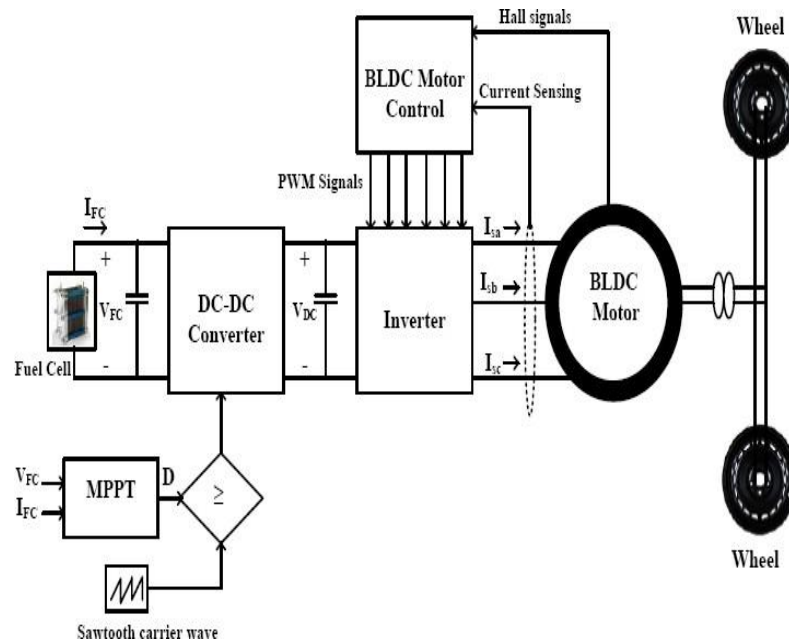

Fig 2. Conventional configuration of cell fed BLDC motor driven electric vehicle

Disadvantages of existing configuration

Poor Reliability Less Efficiency.

Expensive

or Low Power Applications, the standard Boost Converter is utilized as an influence Electronic Interface Whereas for prime Power Applications Boost Converter Won't Be Compatible because of its Low Current Handling Capability and Thermal Management Issues.

To Overcoming These Variable Voltage Gain Dc-Dc Built-In Information.

6. PROPOSED CONFIGURATION WORK

The project proposes excessive voltage acquisition of three single-phase interleaved increase converter (IBC) of power efficient metals for low switching problems and high voltage gains. The method used to save time increases the reliability of the fuel cell and provides high power of FIG. Proposed FCEV displays. FCEV system with high level IBC. It features a 1.26 Kw PEMFC, IBC with a 3-phase high voltage power supply, a voltage source inverter (VSI) and a BLDC motor. The third phase of IBC serves as the interface between PEMFC and VSI. The RBFN-based algorithm, designed to deliver high power to the fuel cell. The I-3-phase IBC provides BLDC vehicle power with VSI. VSI conversion is controlled using BLDC motor electronics. The motor shaft for propulsion is attached to the car wheels.

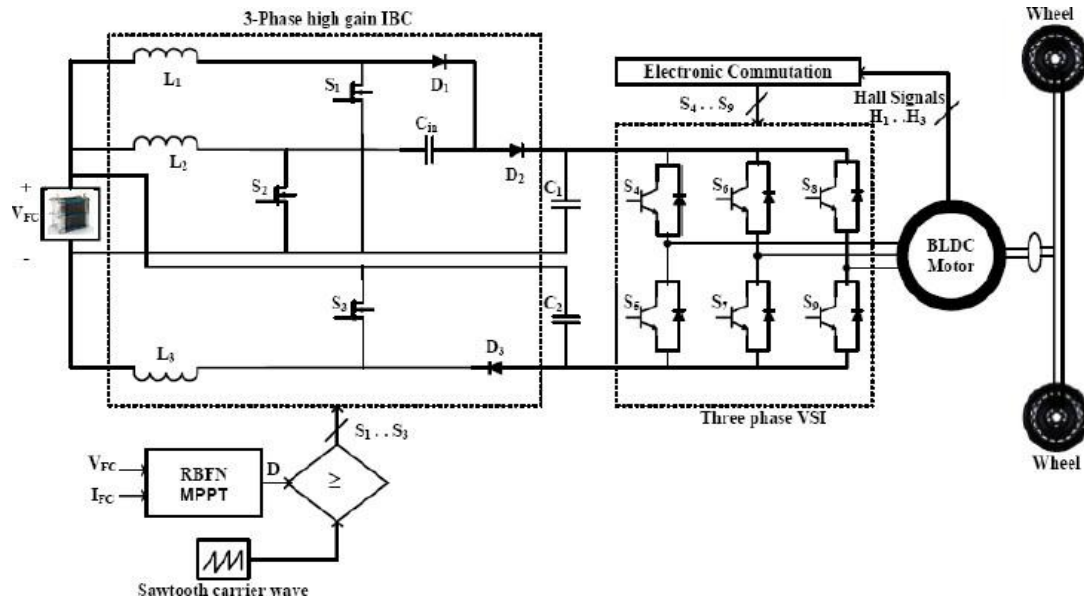

Fig.3. The proposed BLDC motor driven FCEV system with three-phase high voltage gain IBC

Advantages of proposed configuration

1. Clean power generation,
2. High reliability,
3. High efficiency
4. Low noise
5. High voltage gain

Applications

1. Fuel cell applications
2. Solar power applications.

7. FUEL CELL MODELING

A fuel cell is an electrochemical device, it converts hydrogen fuel into electricity. The inputs of the fuel cell are converted into water and electricity by air and fuel and chemical reaction. A single fuel cell consists of two electrodes (anode and cathode) and one electrolyte. The electrolyte separates the positively and negatively charged ions of the hydrogen fuel. When hydrogen and oxygen are supplied into the cell, electricity is generated at the cell's output in the presence of an electrolyte. The scattering fuel cell of the chemical reaction produces only heat and water.

TABLE 1. 1.26kW PEMFC parameter specifications.

Parameter Description	Rating
Maximum power (P_{max})	1.26 kW
Maximum current (I_{max})	52 A
Maximum voltage (V_{max})	24.23 V
Temperature (T)	55°C
Number of cells	42
Nominal air flow rate	2400 lpm

Formulation

$$V_{FC} = E_{Nernst} - V_{act} - V_{ohm} - V_{con}$$

A fuel cell is an electrochemical device that converts hydrogen fuel into electricity. The inputs to the fuel cell are air and fuel and these are converted into water and electricity through a chemical reaction. The cell voltage of PEMFC is given as, Where E_{Nernst} is the open-circuit (or reversible) thermodynamic voltage and is given as,

$$E_{Nernst} = 1.229 - 8.5 \times 10^{-4} (T - 298.15) + 4.308 \times 10^{-5} T (\ln(P_{H_2}) + 0.5 \ln(P_{O_2}))$$

Where T is absolute temperature (K), PO2 and PH2 are oxygen and hydrogen partial pressures (atm) respectively.

Activation voltage Vact is the combination of both anode and cathode activation overvoltage and is expressed as,

$$V_{act} = -[\delta_1 + \delta_2 T + \delta_3 T \ln(C_{O_2}) + \delta_4 T \ln(I_{FC})]$$

Where

i (i= 1,2,3,4) is empirical coefficient for each cell and CO2 is the dissolved oxygen concentration at the liquid/gas interface and is calculated by using the following expression,

$$C_{O_2} = \frac{P_{O_2}}{(5.08 \times 10^6) \times \exp(-498/T)}$$

Ohmic overvoltage Vohm is expressed as

$$V_{ohm} = I_{FC} (R_C + R_M)$$

Where RM is the electron flow equivalent resistance and RC is the proton resistance. RC is considered as constant.

8. THREE-PHASE HIGH VOLTAGE GAIN IBC

The proposed converter consists of three switches (S1, S2 and S3) and three diodes (D1, D2 and D3). L1, L2 and L3 are filters for class 1, phase 2 and phase 3 respectively. VFC is the input voltage, VO is the output power and R is the load resistor. The following considerations are considered in the analysis of the IBC high voltage rating.

Mode-1 ($t_0 \leq t \leq t_1$):

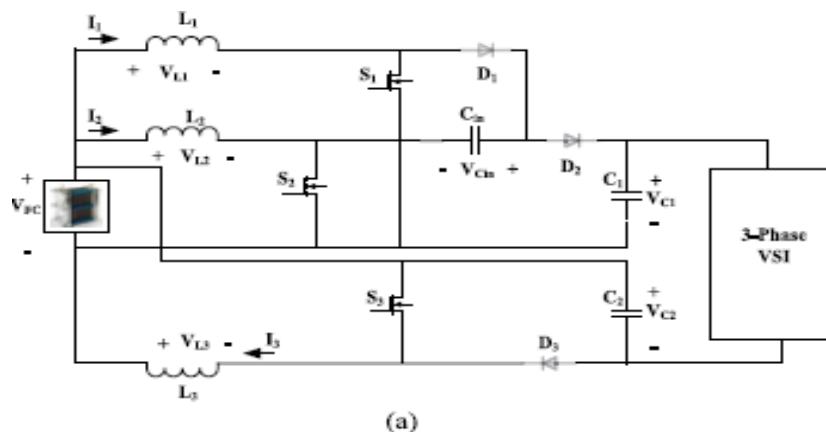

During this time, all three shifts S1, S2 and S3 are turned on ON and all three diodes D1, D2, and D3 are turned back as shown in Fig. 4 (a). VFC input source includes inductors L1, L2 and L3. At the moment using these I1, I2 and I3 spies has increased directly with the slope of (VFC / L). The capacitor input capacitor is disconnected from the load and from supply. The output capacitors C1 and C2 supplies energy to the load resistor and the voltage of output capacitors VC1 and VC2 decreases with a slope of (-VO/RC).

Mode-2 ($t_1 \leq t \leq t_2$):

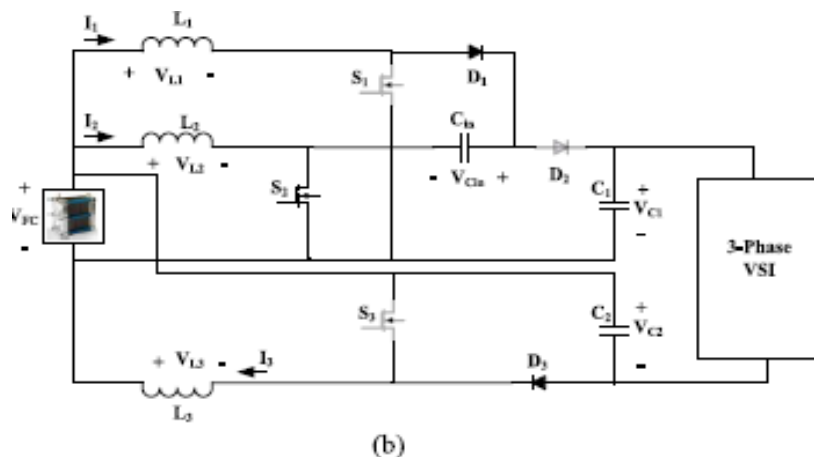

In this mode, the S2 switch is switched on and the S1 and S3 switches are turned off. Diodes D1 and D3 are forward and diode D2 is reversed as shown in Fig. 4 (b). Current within the inductors L1 and L3 decreases with a tendency to $(VFC-VC_{in}) / L$ and $(VFC-VC_2) / L$ respectively. What happens with inductor L2 increases with a slope (VFC / L) . Capacitor C1 supplies power to the loads and capacitors C2 and C_{in} are charged VFC input voltage.

Mode-3 ($t_3 \leq t \leq t_4$): □

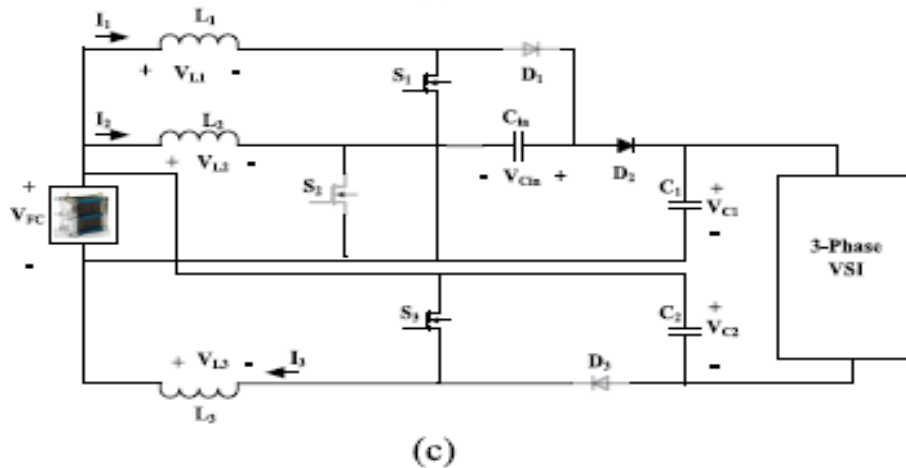

This mode is similar to mode-1. All the three switches S1, S2 and S3 are switched ON and all the three diodes D1, D2 and D3 are switched OFF.

9. CONCLUSION

In this project a three-phase high voltage gain dc-dc converter is proposed for FCEV applications. The proposed converter has reduced the fuel cell input current ripples and the voltage stress on the power semiconductor switches. The simulation results reveal that the RBFN based MPPT controller has tracked the maximum power point faster when compared to the fuzzy logic controller also, different performance characteristics of the BLDC motor such as electromagnetic torque, speed and back EMF are analyzed at different temperatures of the fuel cell system.

10. REFERENCES

- [1] H.-J. Chiu and L.-W. Lin, "A bidirectional DC-DC converter for fuel cell electric vehicle driving system," IEEE Trans. Power Electron., vol. 21, no. 4, pp. 950_958, Jul. 2006.
- [2] B. Geng, J. K. Mills, and D. Sun, "Combined power management/design optimization for a fuel cell/battery plug-in hybrid electric vehicle using multi-objective particle swarm optimization," Int. J. Autom. Technol., vol. 15, no. 4, pp. 645_654, 2014.
- [3] H. Hemi, J. Ghouili, and A. Cheriti, "A real time fuzzy logic power management strategy for a fuel cell vehicle," Energy Convers. Manage., vol. 80, pp. 63_70, Apr. 2014.
- [4] N. Mebarki, T. Rekioua, Z. Mokrani, D. Rekioua, and S. Bacha, "PEM fuel cell/battery storage system supplying electric vehicle," Int. J. Hydrogen Energy, vol. 41, no. 45, pp. 20993_21005, 2016.
- [5] S. Abdi, K. Afshar, N. Bigdeli, and S. Ahmadi, "A novel approach for robust maximum power point tracking of PEM fuel cell generator using sliding mode control approach," Int. J. Electrochem. Sci., vol. 7, pp. 4192_4209, May 2012.
- [6] T. Eswam and P. L. Chapman, "Comparison of photovoltaic array maximum power point tracking techniques," IEEE Trans. Energy Convers., vol. 22, no. 2, pp. 439_449, Jun. 2007.
- [7] S. Saravanan and N. R. Babu, "Maximum power point tracking algorithms for photovoltaic system_A review," Renew. Sustain. Energy Rev., vol. 57, pp. 192_204, May 2016.
- [8] J. P. Ram, N. Rajasekar, and M. Miyatake, "Design and overview of maximum power point tracking techniques in wind and solar photovoltaic systems: A review," Renew. Sustain. Energy Rev., vol. 73, pp. 1138_1159, Jun. 2017.
- [9] L. N. Khanh, J.-J. Seo, Y.-S. Kim, and D.-J. Won, "Power-management strategies for a grid-connected PV-FC hybrid system," IEEE Trans. Power Del., vol. 25, no. 3, pp. 1874_1882, Jul. 2010.
- [10] A. Giustiniani, G. Petrone, G. Spagnuolo, and M. Vitelli, "Low-frequency current oscillations and maximum power point tracking in grid-connected fuel-cell-based systems," IEEE Trans. Ind. Electron., vol. 57, no. 6, pp. 2042_2053, Jun. 2010.