MICROBIAL ENERGY HARVESTING WEARABLES: POWERING THE FUTURE FROM WITHIN

Ankush Tiwari¹

¹Galgotias University, India.

ABSTRACT

The modern demand of smart devices challenges the undeniable need for sustainable energy solutions. The Microbial Energy Harvesting wearables present a fascinating answer which consists of using the energy of our own body to power our devices. This paper dives into the present situation of smart wearables and integrating them with MEH wearables to find out their technological capacity, benefits it gives to environment and also considering the ethical aspects. MEH wearable is not just about an appliance but about a future where our own body fluids facilitate fuel to our gadgets which almost fades the line between human and machines. Smart wearables have become routine device in various fields be it fitness tracking or healthcare. However, the difficulty of managing sustained power choices reduces their usage. Batteries and other conventional energy sources have downsides in terms of weight, size, and environmental effect. Microbial energy harvesting offers a potential workaround for these disadvantages in this situation. This research investigates the feasibility and effectiveness of microbial energy harvesting techniques, mainly microbial electrosynthesis cells (MECs) and microbial fuel cells (MFCs), by integrating nontoxic, spore forming bacterial cells into smart wearable technology.

1. INTRODUCTION

Smart wearable technology comes with a lot of advantages as it permits for easy integration into daily activities and supplies insightful data on lifestyle, fitness, and health. The introduction of this technology has completely transformed the interaction of users with devices. Wearable technology has become an undeniable part of modern living, with everything ranging from fitness trackers that record steps and calories burnt to smartwatches that monitor heart rate and sleep patterns. Another advantage is their ability to operate independently without the hassle of changing the batteries regularly or recharging them. With the introduction of this new technology which is a bit complex to understand at a basic level, there comes a growing need for creative energy-harvesting solutions that can operate for longer periods. Before introducing these devices, the elements such as viability, efficiency, and usefulness of smart wearables used were affected due to the internal cons the traditional batteries had. The most customary type of energy storage in wearable electronics is lithium-ion batteries which are highly popular for their high energy bulk, rejuvenation, and comparatively long life and, are the most common energy source for smart wearables. Lithium-ion batteries have several innate cons that make them inutile for powering wearable technology, even with these benefits that is the finite energy storage capacity of these batteries which means that they must be charged regularly and decline battery health over time and eventually substitution. Furthermore, the size and weight of batteries limit the portability and design of smart gadgets, lowering their contentment and usefulness, especially when it comes to wearable electronics attached to apparel or add-ons. Moreover, the environmental consequences which are associated with technologies involving traditional batteries, which consists of extraction followed by processing, and then disposal of limited materials, embarks upon the importance of environmentally sustainable alternatives. The call for energy sustainability which can reduce the environmental implications of smart wearables is increasing as the demand for wearable technology rises globally due to improvements in healthcare, fitness, and augmented reality applications. This study investigates by studying the microbial culture preparation, setting up of microbial energy harvesting system, studying microbial activity, substrate utilization and using microbial electrosynthesis cells to finally develop the prototype.

2. REVIEW OF LITERATURE

This literature review presents an overview of present research on microbial energy harvesting for smart wearables, underlining the key findings, challenges, and future directions in the area.

Previous results in microbial energy harvesting dating back to the late 20th century, with instigating research by Potter (1911) showing the generation of electricity using microbes or bacteria. Considering that aspect in mind, remarkable improvements have been made in field of microbial metabolism, electron transfer mechanisms, and bio electrochemical processes. The advancement of microbial fuel cells (MFCs) and microbial electro synthesis cells (MECs) has allowed an easy conversion of organic matter into electricity through microbial activity, showing a way for its applications in smart wearables.

The metabolic activity of microorganisms is the main principle of microbial energy harvesting systems to activate electrochemical reactions that generate electrical energy. Electrons are transferred to an electrode surface (anode) when bacteria in MFCs (Microbial fuel cells) oxidize the organic substrate which in turn helps to produce electrical energy. Comprehending the microbial communities involved, kinetics of the substrate utilization and map of electron transfer are crucial for enhancing efficiency of the system in terms of conversion of energy and performance of the system. Researches have been done in recent times to demonstrate the harnessing of the energy of organic substrates from our body for powering different devices. In short conversion of chemical energy into electrical energy. For eg, Guo et al in 2020 developed a wearable microbial fuel cell which generated electrical current from the sweat of our body to supply power to the glucose biosensor for continuous monitoring of glucose levels.

Similarly in the year 2019 Li et al presented an autonomous wearable device for environmental monitoring which got powered through the microbial electrosynthesis cell which converted carbon dioxide (CO₂) into electrical energy

3. RESEARCH METHODOLOGY

With this research we surge to develop a prototype device which is based on the hypothesis that is to create appliance with integration of smart wearables with microbial energy harvesting which will reduce the dependency of these devices on the traditional batteries and will develop an environmental friendly device which gets powered through the energy produced by our body. This hypothesis sets a fundamental step to test the feasibility, viability and effectiveness of this device.

Some of the important things which we need to take under consideration:

- **Microbial Strain:** Microbial strains with acknowledged abilities are selected for their functionality in energy harvesting applications. “*Geobacter sulfurreducens*, *Shewanella oneidensis*, and *Rhodospseudomonas palustris*” are strains that are often used.
- **Culture Maintenance:** Microbial cultures are kept under germ free conditions, either from reliable culture collections or from laboratory isolates to guarantee virtue and feasibility. The growth environment used to breed the cultures provides essential nutrients and substrates for the growth and catabolism of the chosen microbial strains.
- **Acclimation to Experimental Conditions:** Before conducting the experiment the microbial cultures are acclimated to the substrate source, electrode material of the experiment, temperature, and PH . Acclimation improves the microbial adaption and activity, which guarantees optimum performance in microbial energy harvesting systems.
- **Setup of Microbial Energy Harvesting System** For energy generation Microbial fuel cells (MFCs) and microbial electro-synthesis cells (MECs) should be designed, assembled, and optimized as components of the setup of microbial energy harvesting systems. Following steps are used to build microbial energy harvesting systems:
- **Reactor Design:** We either choose glass or plastic reactor vessels to accommodate the exchange of gases, arrangement of electrodes, and the delivery of substrate according to the needs of the experiment. The most suitable organization of the reactor's shape, volume, and surface area helps effectively transferring mass and microbial colonization.
- **Fabrication of Electrodes:** Substances such as carbon cloth, graphite felt, and carbon nanotubes which are conductive in nature are utilized to create the electrodes(anode and cathode) which are further laminated with catalyst and microbial biofilms to improve the electrochemical activity and kinetics associated with the transfer of electrons.
- **Assembly and Integration:** Electrodes are assembled into reactor vessels to assure electrical conductivity and geometric alignment which makes it possible to avoid cross-contamination of electrodes and promotion of ion movement by including separators or proton exchange membranes.
- **Media Preparation:** To catalyze microbial metabolism , Standard laboratory methods are used to produce and disinfect growth media and substrates. Substrates that we will use can be either inorganic (such as carbon dioxide, nitrogen) or organic (such as acetate, glucose).
- **Inoculation:** To begin with metabolic activity and activities involving transfer of electrons, microbial cultures are injected into reactor vessels holding growth media and substrates. Further to advance the growth of microbes and the formation of biofilms on electrode surfaces, densities of inoculation are tuned.

Microbial fuel cells (MFCs) use ' electrogenic activity of microorganisms to generate electricity. Anode, cathode, and proton exchange membrane (PEM) dividing the two electrodes make up MFCs. Anode is the location of microbial oxidation wherein microorganisms oxidize organic substrates and transport electrons to the anode electrode. Oxygen

reduction occurs at the cathode, where protons, oxygen, and electrons from the anode mix to create water as the byproduct. With the help of transport of electrons from the anode to the cathode electrical current is produced which can be captured and used to power external devices. Microorganisms oxidize organic compounds in MFCs, producing electrons as resultant by product in the process of microbial respiration. The direct interaction between microorganisms and electrodes or mediated electron shuttles under extracellular electron transfer(EET), which helps to transmit these electrons to the anode electrode and at the cathode electrode where electrons mix with protons and oxygen to generate water marks the completion of electrochemical circuit. Because the microbial metabolism of microbial fuel cells may use different organic substrates, like biomass, organic waste, and wastewater, as they are flexible and adaptable to a different range of environmental conditions.

ANODE CHAMBER

We have to start with culture preparation followed by substrate addition and then electrode integration in the anode chamber.

Firstly in culture preparation, we will infuse a culture of geobacter sulfurredens which is an electrochemically active bacteria in a medium that is rich in nutrients is Luria-Bertani Broth and let it proceed under anaerobic respiration (under the presence of an innate gate such as nitrogen to prevent the mixing of oxygen) which enhances the formation of biofilm which in turn is useful to improve the efficiency of electrons as it facilitates a direct pathway for electron transfer with the help of conductive matrix.

This will be followed by the addition of a substrate such as glucose or acetate which enhances the microbial metabolism catalysing electron transfer reactions and allowing for energy generation in microbial energy harvesting system which ensures continuous supply of power to the device.

After this we have to ensure the immobilizing of anode electrode in anode chamber and close contact between the microbial biofilm and electrode surface

CATHODE CHAMBER

Electrons will travel from the anode chamber to the cathode chamber so we need to prepare the cathode chamber with an electron acceptor solution (e.g. potassium ferricyanide, oxygen saturated electrolyte) and incorporation of a buffer solution like potassium phosphate buffer which helps in supply of supporting electrolytes for electrochemical reaction and finally the placing the cathode electrode which will act as an electron acceptor and also a catalyst to improve the oxygen reduction reaction The production of electrical current during the process in which microorganisms oxidize organic substances and transfer the electrons to an electrode also known as microbial respiration, is the basis for the functioning of microbial fuel cells (MFCs). Because of the ability of microbial fuel cells (MFCs) to utilize a broad range of organic substrates, such as organic waste, biomass, and wastewater exhibit versatility and adaptability to a variety of situations are used to help microorganisms at the cathode electrode in reducing carbon dioxide or other chemical by producing useful by-products like acetate, hydrogen, and methane.

SEPARATOR SETUP

To prevent the mixing of the components of both the chambers and cross contamination to maintain electrochemical integrity of the system, we have to insert a proton exchange membrane known as Nafium membrane which will allow for an easy transport of protons.

4. EXTERNAL CIRCUIT SETUP

Connect the anode and cathode using a conductive wire to an external circuit through a load resistor (a variable resistor, LED) to measure the electrical output.

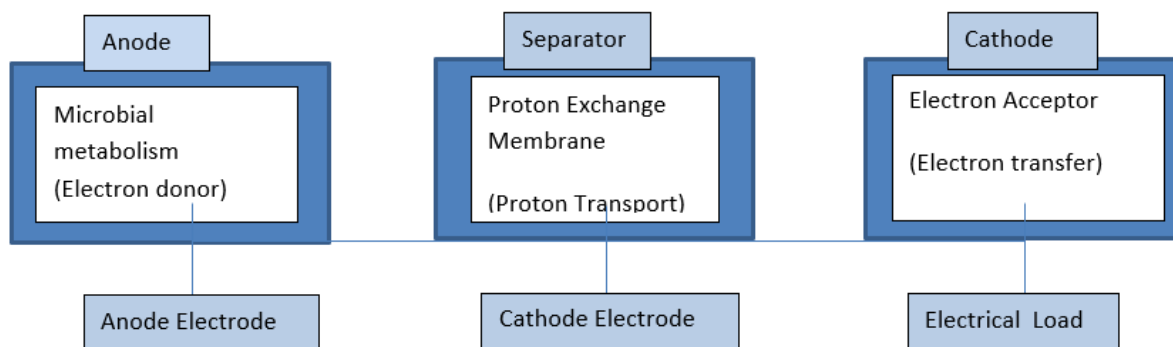

Electrical performance of microbial energy harvesting systems such as microbial fuel cells (MFCs) and microbial electro synthesis cells (MECs) is highlighted by voltage, current, power output, and electrochemical efficiency. The results are as follows:

- **Voltage Generation:** To calculate the electrochemical activity of microbial energy harvesting systems we take voltage measurements into consideration. As it depicts when and how microbial metabolism begins, and how steady-state conditions are established, and how well MFCs or MECs are working overall.
- **Current Production:** In microbial energy harvesting systems, current measurements are made to measure the rate of electron transport and power generation. The dynamics of microbial respiration, substrate utilization, and electron flow within MFCs or MECs are shown by current profiles.
- **Power Output:** The quantitative evaluation of energy transformation efficiency and performance are provided using power output calculations, which are based on voltage and current measurement. Power curves present the relationship between applied load, electrical output, and system performance.
- **Electrochemical Efficiency:** Electrochemical efficiency metrics including Coulombic efficiency, Faradaic efficiency, and energy recovery efficiency are evaluated to assess how well electron transfer and energy conversion processes work. Overall sustainability and performance of the microbial energy harvesting systems are evaluated through efficiency analysis.

Development of prototype refers to designing, creating, and testing wearable technology which consists of microbial energy harvesting systems. The following actions are conducted in order to produce a prototype:

Wearable devices are made theoretically based on practical needs, design limitations, and user needs. Form factor, comfort designs, aesthetics, and integration with constituents which summon microbiological energy are all taken into account.

3D printing, micro fabrication, and flexible electronics are some of the advanced manufacturing methods used to produce prototypes. To ensure comfort, pliability, and body compatibility wearable substrates like fabrics, elastomers, or biocompatible materials are taken into consideration

Using particularly made electrodes, biocompatible membranes, and encapsulating materials, microbial energy harvesting systems are included into wearable technology. The longevity, electrical connectivity, and effective energy conversion of the wearable are all guaranteed by the integration process.

5. CONCLUSION

The introduction and the quick development in the field of wearable technology made a significant impact on different sectors like health care sector, fitness tracking, communication and entertainment. It also comes up with undeniable benefits through devices like smartwatches, fitness trackers, and augmented reality glasses for attributes like their usefulness, association and seamless interaction into daily activities. There are some of the challenges as well associated with the usage of smart wearable technology on integration with microbial energy harvesting technology like power volition, size of the device and the concern of environmental sustainability Along with the wide range of promising solutions offered by microbial energy harvesting technologies for sustainable energy generation, there come several challenges also which needs to be addressed to understand their full potential. **Energy Conversion Efficiency:** One of the most important and primary challenges in microbial energy harvesting is to improve the efficiency of energy conversion. Microbial fuel cells (MFCs) and microbial electrosynthesis cells (MECs) usually offer lesser power output and energy conversion efficiency because of the influencing factors such as electrode fouling, microbial competition, and incomplete utilization of substrate. Enhancing electron transfer kinetics, optimizing reactor design, and selecting suitable microbial strains. It becomes difficult for improving energy conversion efficiency in microbial energy harvesting systems. **Long-Term Stability and Reliability:** It is important to ensuring the long-term stability and reliability of microbial energy harvesting systems to ensure its better practical applications. Many of the challenges such as electrode degradation, biofilm dissociation, and microbial contamination come up because of which we may have to compromise on the performance of the system and its durability. As a result of which it is necessary to develop robust materials, implementing effective maintenance strategies, and enhancing system analyse and control to address longevity and trust issues in microbial energy harvesting. **Scalability and Commercialization:** Microbial energy harvesting comes up with important technical and economic problems during its upgradation from laboratory prototype to commercial-scale system. To look for widespread adoption of microbial energy harvesting solutions it is important to consider the factors such as cost of the electrode, reactor expandability, and regulatory adherence. Equal involvement of academic agency, industrial agency, and government agencies is crucial to tackle the barriers of scalability and allowing the commercialization of microbial energy harvesting technologies.

6. REFERENCES

- [1] T Huynh, H. Haick, “Autonomous flexible sensors for health monitoring,” *Advanced Materials*, 30, 1802337, 2018.
- [2] M. Wang, Y. Yang, J. Min, Y. Song, J. Tu, D. Mukasa, C. Ye, C. Xu, N. Heflin, J.S. McCune, T.K. Hsiai, Z. Li, W. Gao, “A wearable electrochemical biosensor for the monitoring of metabolites and nutrients,” *Nature Biomedical Engineering*, 2022, in-print, 10.1038/s41551-022-00916-z
- [3] A.K. Yetisen, J.L. Martinez-Hurtado, B. Unal, A. Khademhosseini, H. Butt, “Wearables in medicine,” *Advanced Materials*, 30, 1706910, 2018.
- [4] X. Zhang, M.C. Schall Jr., H. Chen, S. Gallagher, G.A. Davis, R. Sesek, “Manufacturing worker perceptions of using wearable inertial sensors for multiple work shifts,” *Applied*
- [5] OpenAI. (2023). ChatGPT (3.5 version) . <https://chat.openai.com/chat>