THE DEVELOPMENT AND EVALUATION OF A CURVED SURFACE ANTENNA ARRAY FOR USE IN 5G TECHNOLOGY

Sadiya Masood Khaki¹, Dr. Vivek Arora²

¹M. Tech Scholar, Ganga Institute Of Technology & Management Kablana Jhajjar, India.

²Assistant Professor, Ganga Institute Of Technology & Management Kablana Jhajjar, India.

ABSTRACT

The need for effective and high-performing antenna systems has increased as 5G technology has spread. Particularly in complicated situations, antenna arrays installed on curved surfaces offer special benefits in terms of beamforming, directivity, and coverage. This thesis offers a thorough investigation into the planning and evaluation of antenna arrays intended especially for 5G applications and placed tactically on curved surfaces.

The first stage of this research entails a comprehensive analysis of the body of literature in order to comprehend the underlying ideas, difficulties, and most recent developments in antenna array design for 5G networks. The emphasis then turns to the creation of novel design techniques that are tailored for curvature surfaces and take into consideration elements like radiation pattern shaping, mutual coupling, and curvature effects.

A variety of antenna array topologies are investigated and analysed using sophisticated simulation tools and optimisation techniques in order to get superior performance metrics, such as high gain, low sidelobe levels, and improved beam steering capabilities. We carefully examine how curvature affects the radiation properties of the array and how it affects 5G system factors including capacity, coverage, and spectral efficiency.

Furthermore, in order to provide a smooth integration with contemporary communication infrastructure, this research explores unique fabrication processes appropriate for realising antenna arrays on curved substrates. Manufacturability, cost-effectiveness, and scalability are among the practical factors that are taken into account to help proposed ideas move from theoretical conceptions to actual applications.

Lastly, through modelling and prototyping, comprehensive validation experiments and performance evaluation are carried out, proving the effectiveness of the suggested antenna arrays for a range of 5G use cases, such as large MIMO systems, mmWave communication, and Internet of Things applications. The research presented in this thesis advances the field of antenna array technology and offers important new information for the planning and implementation of 5G networks in a variety of settings.

Key Words: Antenna array, 5G technology, Antenna optimization, Array design, Antenna testing

1. INTRODUCTION

The need for ultra-low latency, huge connection, and high-speed data transfer has spurred research into new antenna technology in the era of fifth-generation (5G) wireless communication. Thanks to their ability to provide beamforming, spatial multiplexing, and effective spectrum utilisation, antenna arrays have become essential elements of 5G networks. Conventional antenna array implementations, however, frequently run into issues when used in tight spaces or complicated situations with uneven surfaces.

The design and analysis of antenna arrays placed strategically on curved surfaces is the main topic of this thesis, which offers a novel solution to the problems that arise when 5G applications are used in such surroundings. Through the utilisation of curved surfaces' special advantages—such as better beam shaping, increased coverage, and decreased interference—this study attempts to create novel antenna array arrangements that are tailored for 5G communication systems.

An extensive examination is required since the placement of antenna arrays on curved surfaces presents a number of fascinating engineering issues. The radiation properties of the antenna elements are influenced by the curvature of the mounting surface, which has an impact on variables including gain, directivity, and polarisation. Furthermore, on curved surfaces, mutual interaction between closely spaced parts becomes more prominent, requiring advanced design strategies to reduce its impact.

This thesis investigates the practical implications of constructing and installing antenna arrays on curved surfaces, in addition to addressing technological problems. The successful realisation of these antenna systems depends on factors including material selection, manufacturing procedures, and interaction with current infrastructure. Moreover, the feasibility of the suggested designs for extensive implementation in 5G networks is contingent upon their scalability and cost-effectiveness.

This discovery is important because it has the potential to completely change how antenna systems are designed and implemented for 5G applications, especially in situations where more traditional methods are inadequate. Through the utilisation of curved surfaces and sophisticated design techniques, it is anticipated that the suggested antenna arrays will provide better efficiency, more dependability, and greater flexibility in a range of operational conditions.

An extensive examination of antenna array design principles, analysis methods, optimisation strategies, and experimental validation will be provided in the next parts of this thesis. This research aims to make a significant contribution to the field of 5G antenna technology by means of theoretical investigations, modelling studies, and actual experiments. The ultimate goal is to pave the way for the realisation of next-generation wireless communication networks.

2. ANTENNA

An antenna is a system of conductors which mainly consists of transmitter and receiver.

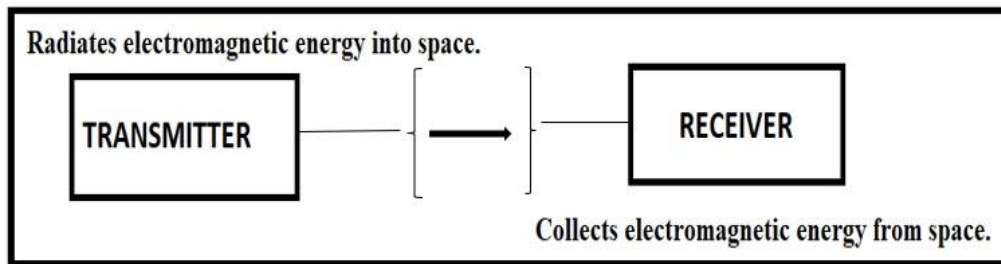

Figure: 1 Basic Communication System

Antenna Gain

It is termed as a potential of the antenna to radiate in any direction which can be more or less in comparison to a theoretical antenna.

Antenna Efficiency

An antenna efficiency will be high when the power which is present at input radiates away at most while it will be low when it will get absorbed or reflected away. It can be due to impedance mismatch.

Effective Area

$$P = pA_e \quad (1.1)$$

where P = power present at the terminals of antenna in Watt

p = power density of antenna A_e = effective aperture

Return Loss

It shows the quantity of electricity that is lost to the load and is not reflected back.

When a graph shows a dip at the operating frequency of the antenna with a minimum

dB value at this frequency then it can be considered as better performance of an antenna.

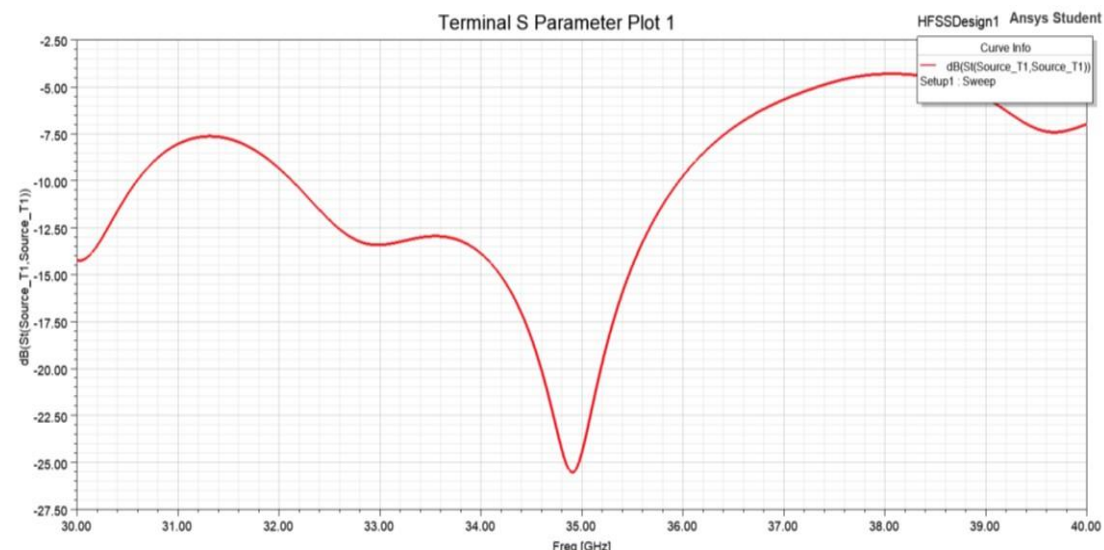
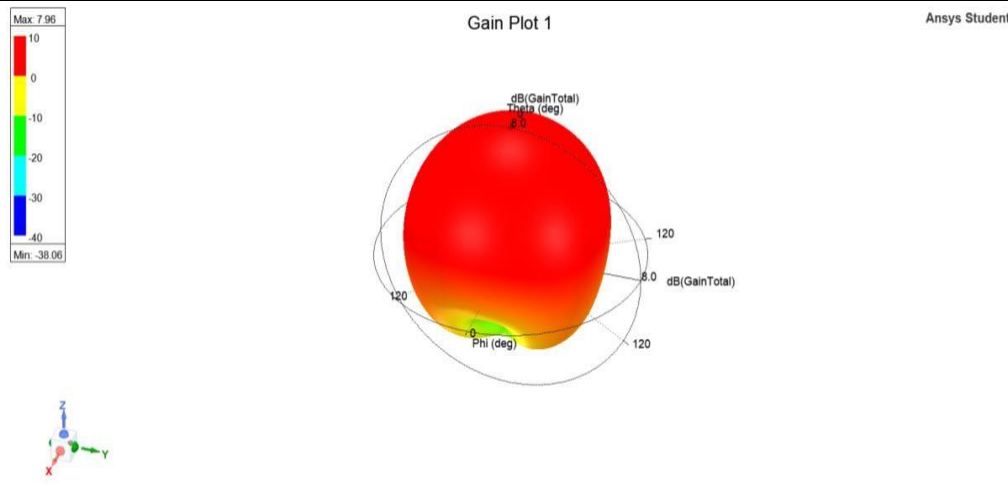

Figure: 2 Return loss curve of an antenna



Radiation Pattern Beamwidth

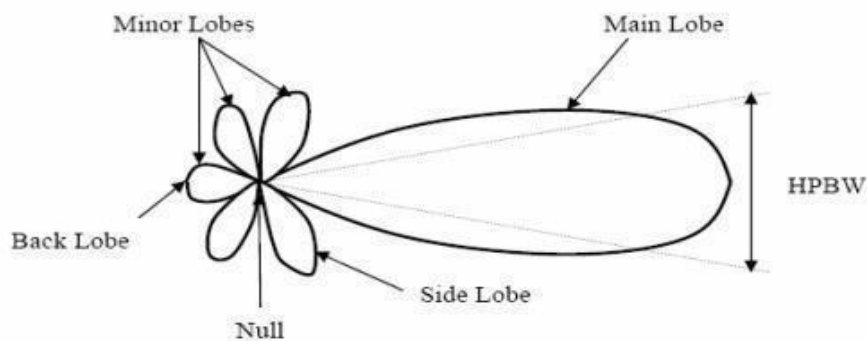

Figure:3 Determination of HPBW from 2D radiation pattern

3. CLASSIFICATION OF ANTENNAS

They can be categorised on the basis of various factors that are entangled in the working of an antenna. It can be the frequency band in which antenna is operating or the physical structure and design. They can be nondirectional such as dipoles or monopoles which are simple or directional antennas which are more complex such as microstrip antenna, array etc. With the advancement of wireless communication technology, 5G can be considered as an upcoming new generation in the area of wireless mobile communication systems. And it has developed a new type of antenna which are referred as conformal antenna in which an antenna or antenna array are wrapped around the surface of curvature. These type of antennas shows better results and can be used in aircraft and missiles applications.

4. OBJECTIVES

The objectives of this research are:

- Design a curved surface antenna array specifically tailored for optimal performance with 5G technology.
- Assess the effectiveness of the curved antenna array in practical 5G situations.
- Examine the scalability of the curved antenna array for different 5G deployment scenarios.
- Improve the radiation pattern of the curved antenna array to boost 5G coverage.
- Evaluate the antenna's capacity to meet the demanding requirements of 5G networks, including high data rates and low latency.
- Evaluate the influence of antenna curvature on beamforming and signal propagation in 5G scenarios.
- Assess the practicality of incorporating the curved antenna array into the current 5G infrastructure.
- Examine the durability of the antenna array design in relation to environmental conditions in 5G deployment sites.
- Create streamlined manufacturing methods for generating the curved surface antenna array on a large scale.
- Assess the cost-effectiveness of implementing the curved antenna array to achieve extensive coverage of the 5G network.

5. LITERATURE REVIEW

Some works from the literature which has done research in this area are shown in this section.

J. Colaco et al., [2020] In developing nations like India, there may be a need for continuous, excessive streaming online education that uses a lot of bandwidth and expensive data storage. As a result, the authors of this study have created a microstrip patch antenna for use in unique 5G programmes and online training that utilises 5G millimetre wave bands at a resonant frequency of 26 GHz. The square patch utilised in this suggested design has a dielectric regular of 2.2 and a dielectric loss tangent of 0.0010. FEKO software tool is used to analyse and simulate the format. Following modelling, authors discovered a great go back loss of -33.4 dB, a suitable bandwidth of 3.56 GHz, VSWR of 2 and a surplus advantage of 10 dB, as well as an antenna radiation efficiency of 99.5%. This suggested configuration is advantageous when the arena is under a lockdown scenario. [1]

M. Stanley et al., [2019] Brief updates in distant correspondences call for a reception device that can function at twice as many repeat companies in a smaller size. 5G faroff transactions may use 28 GHz and 39 GHz repetition groups, a dual-band, dualspellbound receiving wire is now being suggested. The suggested radio wire is a twofold polarizable bend parasitic element receiving cord

with layered capacitive coupled restoration. Details on the receiving twine execution and form gauges are provided. The radio cable has a very fast changeover speed in both repetition groups and covers the frequencies of 25.75-30.25 GHz and 36.541 GHz. The proposed receiving wire section's zenith gain is 7.14 dBi with in lower band and 6.44 dBi as in better band. Due to its reduced length, the radio wire segment may be used in practical devices' receiving cord clusters. [2]

S. Kim, et al., [2019] For transferring target detecting applications, A 24 GHz Doppler radar receiver with great imprisonment is shown. Each Tx and Rx radio wire has two 2x2 microstrip repair screens. The suggested radio wire's high division is achieved by inserting a unique Jerusalem pass beginning point between the Tx and Rx ports. Along these traces, the ground wave from the Tx port to the Rx port is completely covered. The suggested reception equipment has a - 10 dB mirrored image coefficient statistics transmission potential of 510 MHz, and the detachment between the Tx and Rx ports is more than 36.7 dB across the 24 GHz ISM band. For E-aircraft and H-plane, the mimicked half-energy beam widths are 58.53° and 47.54°, respectively. Initial results indicate that excessive isolation might encourage better Doppler radar performance. The suggested radio cord would now not be too bad of a competitor for touch-free monitoring of the heartbeat and respiration rate in recovery administrations programmes. [3]

Z. Gan, et al., [2018] For IEEE 802.11 a (45 GHz) software, a millimeter-wave substantially spellbound (CP) four by four-millimetre wave radio cable demonstration composed of innovative microstrip reception apparatus components are shown. A three dB hub share (AR) transmission capacity of 17.3% and an impedance switch pace of 24.9% are achieved by adding L-shaped branches and condensed corners to the microstrip receiving wire phase. The degree diversity and adequacy ratios of 180° and 90° electric region pieces at (0,0, r) are investigated to determine the effects of Lformed divisions and shortened corners. For the CP receiving apparatus show off, a simpler and smaller microstrip sustaining framework is intended, and the suggested cluster is implemented using two-layer PCB sheets.

The outlet decrease on the middle ground connects the electromagnetic need from the supporting framework to the radiators. From 51.9 to 49.1 GHz, the receiving cord cluster's conscious three dB AR information transmission is 16%, and the deliberate expansion is all more crucial than 17 dBi in the range from 41 to 49 GHz. [4]

D. Shin et al., [2015] A revolutionary microstrip fix receiving wire is suggested for use in automobiles. Radio wire configuration has been analysed using parametric analysis and surface stream display upon that receiving wire structure. By connecting the short parasitic component, the surface streams related to cross-polarization are decreased and those linked to co-polarization are expanded. The four different single receiving wire types are anticipated to take cross-polarization level and increment into consideration. The differentiated and rhombic receiving devices have lowered the cross-polarization level of the planned radio wire by 5.9Db.

The input reflection coefficient and radiation execution of the suggested exhibit radio wire and rhombic cluster reception equipment were built and pursued. The findings that were deliberate and reenacted have been shown and debated. [5] It can be observed that cylinder is mostly used as carrier for conformal antennas. References found are on similar type of geometry. We will find very few literatures when design and analysis is done on conical, elliptical or other geometries.

6. METHODOLOGY

ANTENNA DESIGN

A RECTANGULAR MICROSTRIP PATCH ANTENNA

To design a rectangular microstrip patch antenna, firstly we chose the material for substrate. To minimize the loss, substrates with low loss tangent dielectric reduces the dielectric loss. And to minimize the radiation loss, small substrate height is preferred. considering these factors, following dimensions have been taken into account.

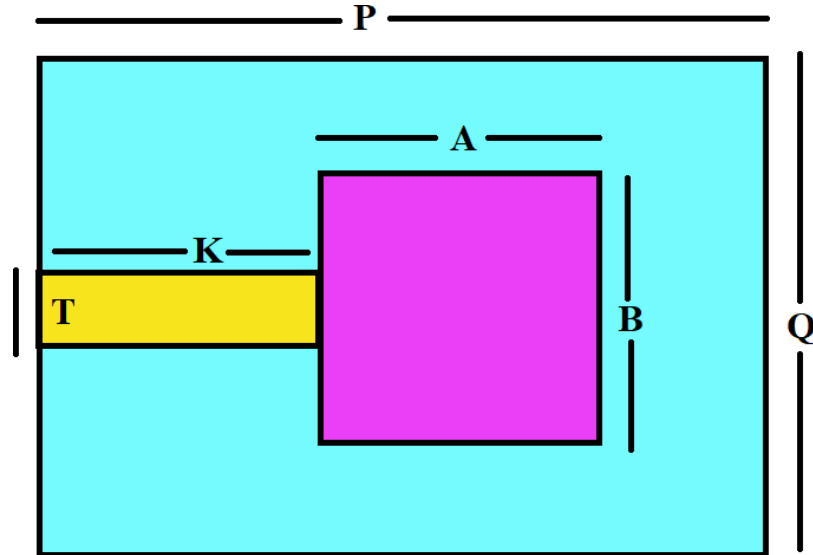

Figure:4 The model of rectangular microstrip patch antenna

Table.1 Dimensions of Rectangular Microstrip Antenna

S.No.	Parameters	Dimensions
1.	P (Length of substrate)	6mm
2.	Q (Width of substrate)	6mm
3.	A (Length of patch)	2.45mm
4.	B (Width of patch)	3.32mm
5.	K (Length of microstrip feed)	1.57mm
6.	T (Width of microstrip feed)	0.46mm
7.	H (Height of substrate)	0.5mm
8.	Relative permittivity of dielectric material	2.2

Microstrip line feeding, coaxial feeding and electromagnetic coupling are used to feed the microstrip antenna.

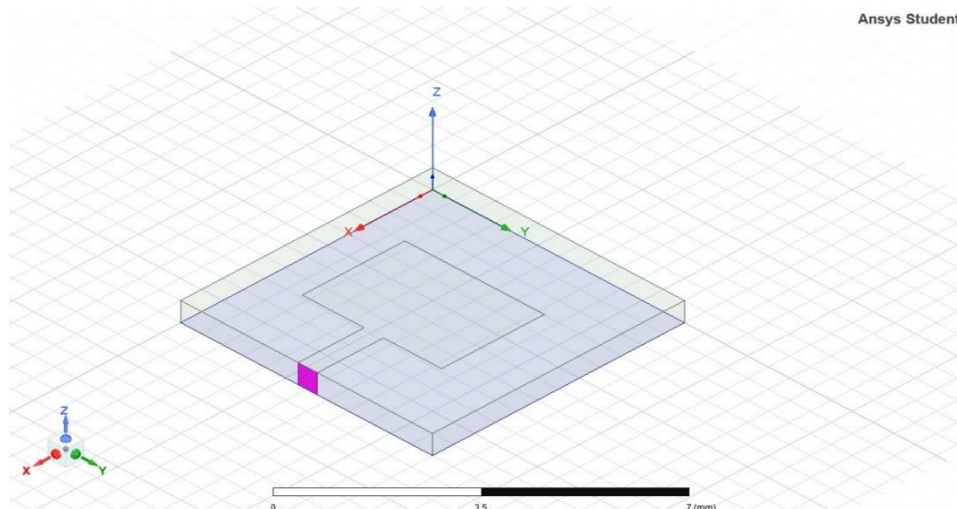

Figure :5 Simulated Microstrip Patch Antenna

The line width is taken as 0.46mm and the characteristic impedance is 50 Ω.

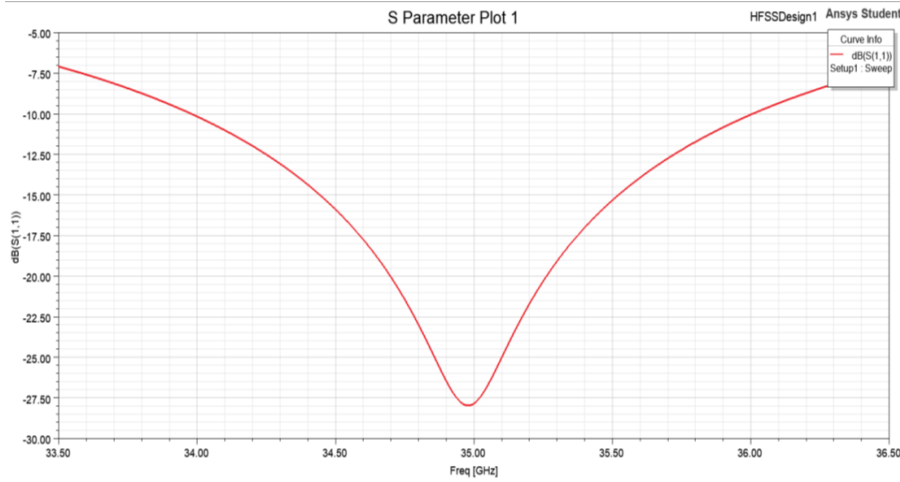

Figure :6 S-parameter vs Freq curve of rectangular microstrip patch antenna.

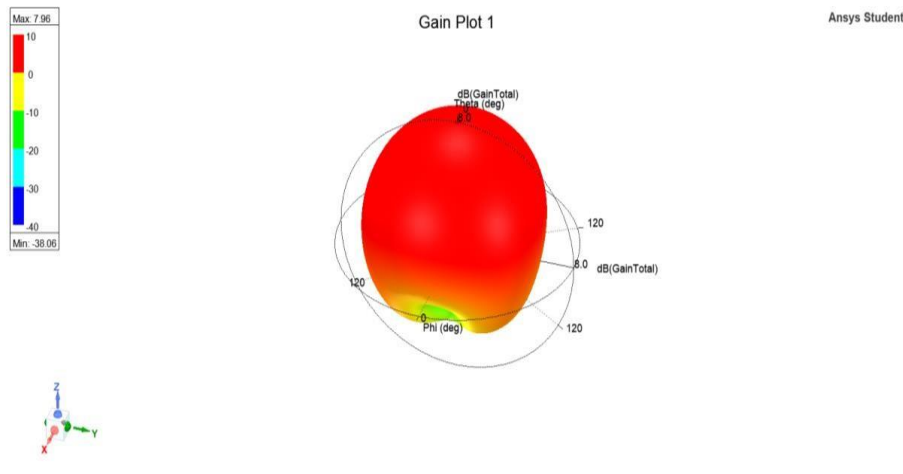

Figure:7 3D Polar plot of rectangular microstrip patch antenna

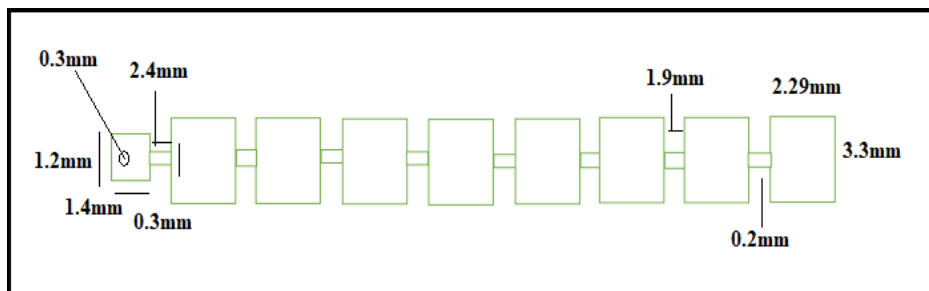

Figure:8 Model of Antenna Array with One-End Coaxial Feed

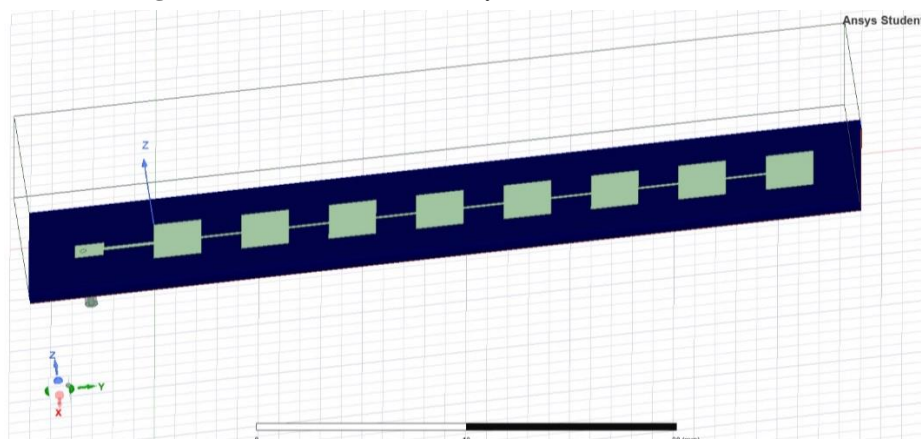

Figure :9 imulated an eight-element array with one-end coaxial feed

The simulation is performed on HFSS simulation software. Figure 4.3 is a representation of S-parameter vs Frequency (GHz) curve of rectangular microstrip patch antenna. It clearly shows that return loss has been found to be -28 dB at 35 GHz. So consequently, the relative bandwidth for $|S_{11}| < -10\text{ dB}$ is evaluated from the Figure 4.3 as 5.74%.

AN ANTENNA ARRAY WITH ONE-END FEEDING

A rectangular microstrip series fed array is designed to reduce the return loss as less than -10 dB and to achieve high gain & bandwidth. It is an eight-element antenna array which is connecting a microstrip line. The first patch element is fed with a coaxial line.

The rectangular microstrip patches are of same shape and the spacing between them is same. The array is attached to the 50ohm coaxial line feed.

7. PROPOSED ANTENNA DESIGN

The conformal array is designed and the conformal carrier is taken as cylinder, cone and sphere surface of curvature.

In this section, the focus is to determine the effect of parameters of a single antenna array which is conformed on a cylindrical, conical and spherical structure such as radius of carrier, thickness of substrate and the substrate permittivity. We have taken return loss, gain and bandwidth into consideration for the comparative study of different curvatures.

THE MICROSTRIP ANTENNA CONFORMAL ARRAY ON CYLINDER CURVATURE SURFACE

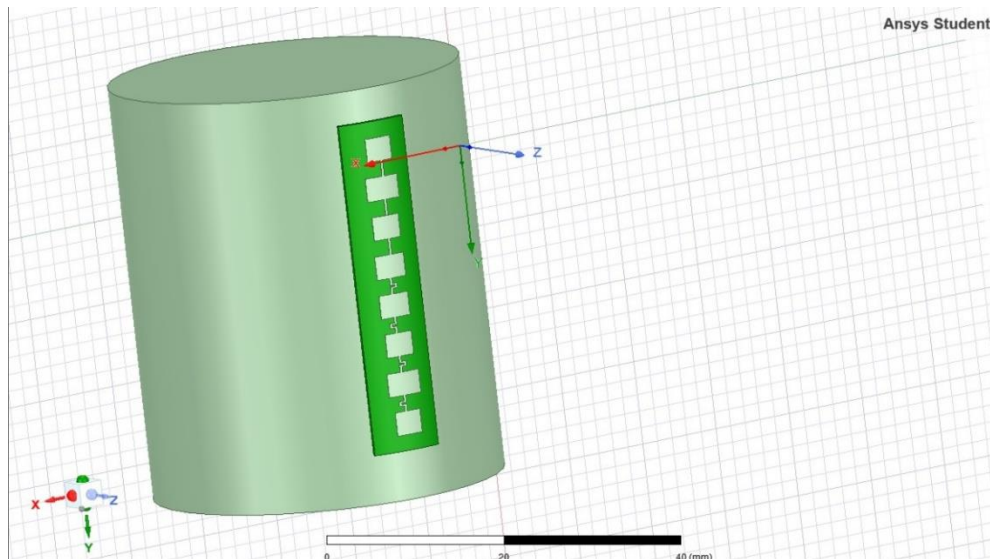

Figure:10 Conformal antenna array on cylinder surface

By Varying the radius of curvature

We have varied the radius of curvature from 30mm to 50mm and observed the following results.

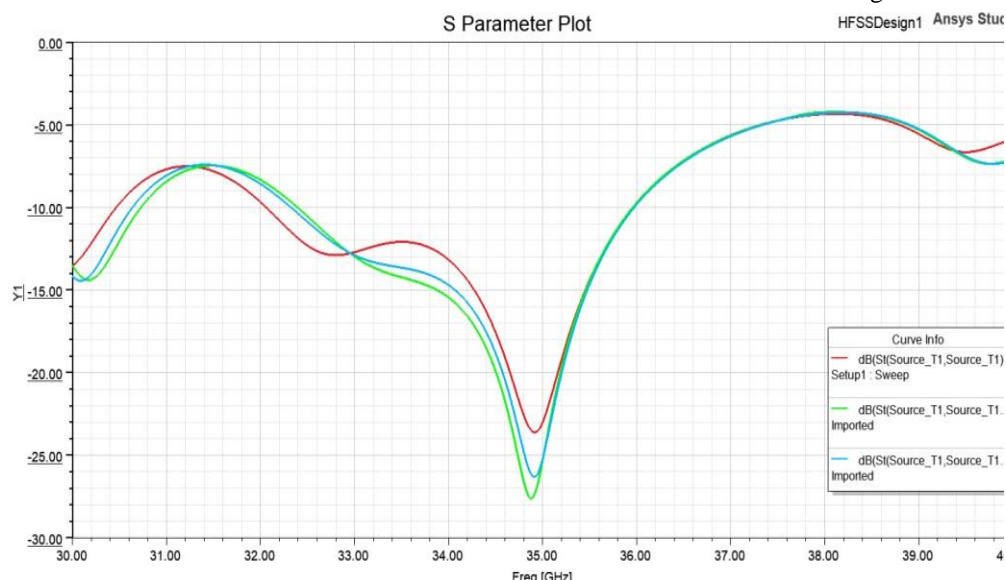

Figure:11 S Parameter vs Frequency Plot of Cylindrical Curvature

In Figure , it can be clearly seen that there is a very little variation in the value of return loss when we have varied radius of cylinder from 30 mm to 50 mm.

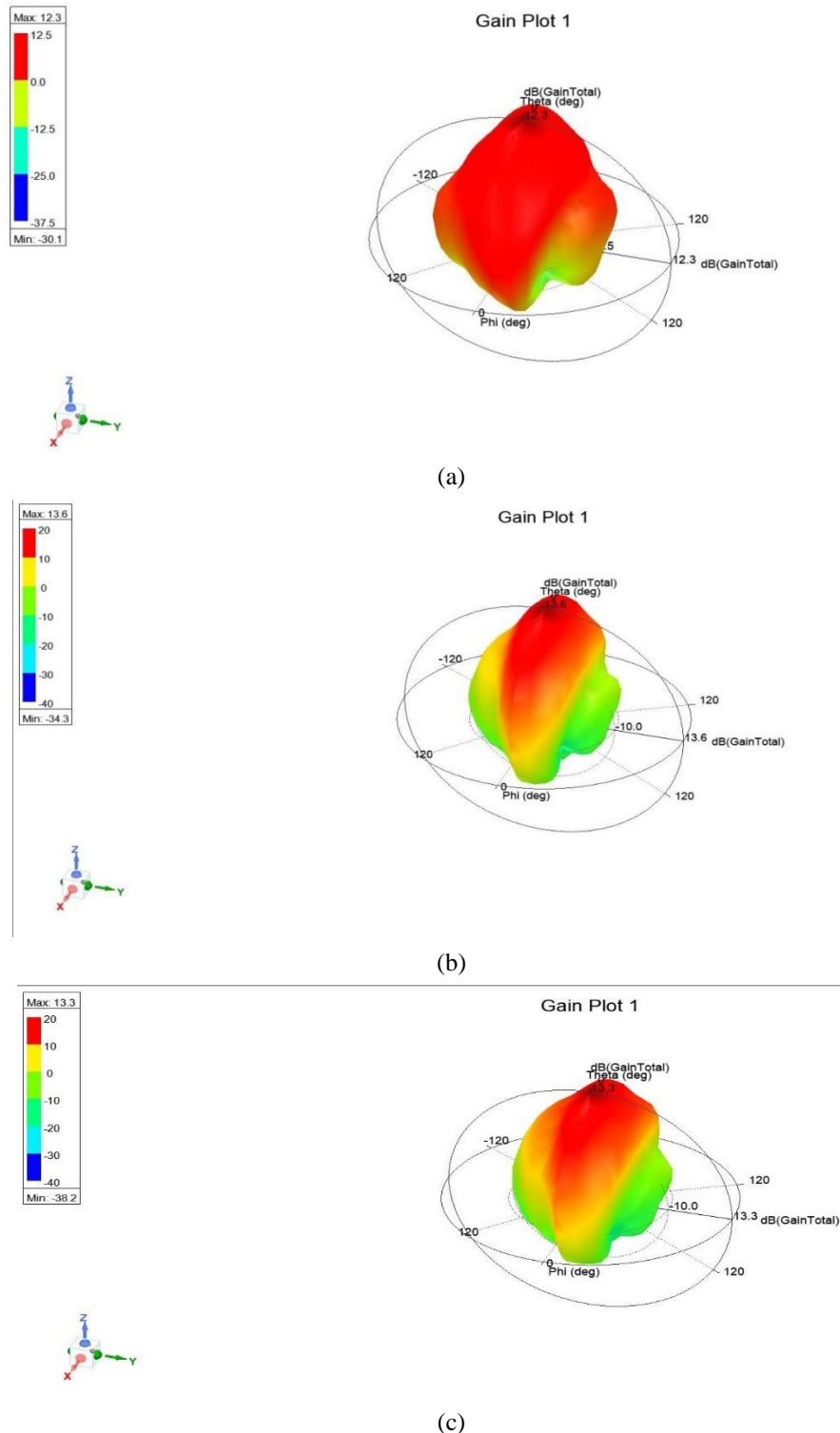

Figure :12 3D Polar Plot for radii (a) 30 mm (b) 40mm (c) 50mm

It can be observed that maximum gain is achieved at radius of 50mm of about 13.6 dB.

Table: 2 Comparative Results at different radius of curvature

Radius	Return Loss	Bandwidth	Relative Bandwidth	Gain
30 mm	-26.2953	2.575	10.45%	12.3
40 mm	-27.5336	3.65	10.68%	13.3
50 mm	-23.6023	3.90	11.46%	13.6

8. RESULTS AND CONCLUSIONS

COMPARATIVE STUDY

Type Of Antenna		ReturnLoss	Resonant requency	Bandwidth	Gain
Microstrip	PatchAntenna	-28	35	2.00	7.96
Antenna Array with oneend feeding		-23.50	35.50	7.20	13.5
Antenna Array withintermediate feeding		-26.50	35	9.8	13.4
Conformal antenna array on cylindrical curvature	R=30mm	-26.29	34.7	2.57	12.3
	R=40mm	-27.53	34.8	3.65	13.3
	R=50mm	-23.60	34.9	3.90	13.6
	$\epsilon_r=1$	-31.58	34.9	3.87	13.9
	$\epsilon_r=2.2$	-26.29	34.7	2.57	12.3
	$\epsilon_r=4.4$	-12.89	31.2	0.52	3.6
	H=0.5mm	-31.29	34.9	2.57	12.3
	H=1.6mm	-35.72	35.7	7.52	13.41
Proposed Design					
Conformal antenna array onconical curvature	R=30mm	-24.06	35.20	7.22	12.7
	R=40mm	-24.82	35.40	7.40	13.0
	R=50mm	-26.56	35.50	7.60	13.3
	$\epsilon_r=1$	-33.83	36.25	7.98	13.5
	$\epsilon_r=2.2$	-24.06	35.20	7.22	12.7
	$\epsilon_r=4.4$	-15.93	32.20	6.56	9.7
	H=0.5mm	-24.06	35.20	7.22	12.7
	H=1.6mm	-24.90	36.33	9.52	13.1
Conformal antenna array onspherical curvature	R=30mm	-34.23	35.31	9.90	12.60
	R=40mm	-37.35	35.35	9.375	12.81
	R=50mm	-38.43	35.75	10.01	13.97
	$\epsilon_r=1$	-43.73	34.38	11.77	13.94
	$\epsilon_r=2.2$	-38.43	34.31	9.900	12.60
	$\epsilon_r=4.4$	-29.65	34.61	8.88	7.6
	H=0.5mm	-38.43	34.31	9.900	12.60
	H=1.6mm	-39.89	35.75	11.49	13.50

It shows how return loss, bandwidth and gain varied with different curvature, radiusof curvature, relative permittivity and thickness of substrate.

9. CONCLUSIONS

With the help of this present work, we are able to analyse the effect of different curvature surface for conformal antenna. The results of conformal antenna are far better than the results of microstrip patch antenna and antenna array. When an antenna array is conformed on cylindrical, cone and spherical curvature then performance of array has become better and it shows better results.

Between cylindrical and conical conformed antenna, we can observe that conical has better return loss value and broad bandwidth and gain in comparison to cylindrical.

And among three curvature surfaces, we can easily determine that spherical has shown thebest results. And it can be the area of new research for wireless communication systems.

The parametric analysis done on physical parameters is an important tool to analyse the performance of an antenna characteristics. We have successfully designed, simulated and analysed the different antenna designs in this project work.

10. REFERENCES

- [1] Mishra, P. and Gupta, P., Compact U-Slotted Dual Band Conformal Microstrip Antenna.
- [2] Redondo Gonzalez, M.D.C., 2007. Analysis of Conformal Antennas for Avionics Applications (Doctoral dissertation, Chalmers University of Technology).
- [3] Naik, K.K., Sri, P.A.V. and Srilakshmi, J., 2017, November. Design of implantable monopole inset-feed c-shaped slot patch antenna for bio-medical applications. In 2017 Progress in Electromagnetics Research Symposium-Fall (PIERS-FALL) (pp. 2645-2649). IEEE.
- [4] Wang, Q., Mu, N., Wang, L., Safavi-Naeini, S. and Liu, J., 2017. 5G MIMO conformal microstrip antenna design. *Wireless Communications and Mobile Computing*, 2017.
- [5] Sun, D., Shen, R. and Yan, X., 2014. A broadband conformal phased array antenna on spherical surface. *International Journal of Antennas and Propagation*, 2014.
- [6] Gottwald, G. and Wiesbeck, W., 1995, June. Radiation efficiency of conformal microstrip antennas on cylindrical surfaces. In *IEEE Antennas and Propagation Society International Symposium. 1995 Digest (Vol. 4, pp. 1780-1783)*. IEEE.
- [7] K.-L. Wong and S.-Y. Ke, "Cylindrical-Rectangular Microstrip Patch Antenna for Circular Polarization", *IEEE Tran. On Antennas and Prop.*, Vol. 41, No. 2, February 1993.
- [8] Q. Jinghui, Z. Lingling, Du Hailong and Li Wei, "Analysis and Simulation of Cylindrical Conformal Omnidirectional Antenna", *Microwave conference Proceedings, 2005. Asia-Pacific Conference Proceedings. Vol. 4, Dec. 2005*.
- [9] Lars Josefsson and Patrik Persson, "Conformal Array Antenna Theory and Design", Wiley-IEEE Press, March 2006. pp. 1-5, 230-238, 265-302.
- [10] C. A. Balanis, "ANTENNA THEORY. Analysis and Design", John Wiley & Sons Inc., Second Edition, 1007. pp. 722-772.
- [11] Li, E., Li, X.J. and Seet, B.C., 2021. A Triband Slot Patch Antenna for Conformal and Wearable Applications. *Electronics*, 10(24), p.3155.
- [12] Sahoo, R., Vakula, D. and Sarma, N.V.S.N., 2017, November. A wideband conformal slot antenna for GPS application. In 2017 Progress in Electromagnetics Research Symposium-Fall (PIERS-FALL) (pp. 589-592). IEEE.
- [13] Aziz, M.A., Roy, S., Berge, L.A., Nariyal, S. and Braaten, B.D., 2012, March. A conformal CPW folded slot antenna array printed on a Kapton substrate. In 2012 6th European Conference on Antennas and Propagation (EUCAP) (pp. 159-162). IEEE.
- [14] Gupta, N.P., Kumar, M. and Maheshwari, R., 2019, August. Development and performance analysis of conformal UWB wearable antenna under various bending radii. In *IOP Conference Series: Materials Science and Engineering (Vol. 594, No. 1, p. 012025)*. IOP Publishing.
- [15] Löcker, C., Vaupel, T. and Eibert, T.F., 2005. Radiation efficient unidirectional low-profile slot antenna elements for X-band application. *Advances in Radio Science*, 3(B. 1), pp.143-146.