

## SOLID WASTAGE MANAGEMENT SYSTEM FOR SMART CITIES

S. A Mansoor<sup>1</sup>, M. Pavan Kumar<sup>2</sup>, Gowd N. Chandra<sup>3</sup>, Mohan S. Mansoor Basha<sup>4</sup>,  
V. Kiran Kumar Reddy<sup>5</sup>, A. Charan Sai Raj<sup>6</sup>

<sup>1</sup>Assistant Professor, Department Of ECE, Dr.K.V.Subbareddy institute of Technology, Dupadu Railway Station, NH-44,Laksmipuram – Post, Kurnool, Andhra Pradesh 518218, India.

<sup>2,3,4,5,6</sup>B. Tech scholars , Department Of ECE, Dr.K.V.Subbareddy institute of Technology, Dupadu Railway Station, NH-44,Laksmipuram – Post, Kurnool, Andhra Pradesh 518218, India.

### ABSTRACT

The "Solid Waste Management System for Smart Cities" is a pioneering project designed to address the challenges of waste management in urban environments. Leveraging the power of ESP32 microcontroller, ultrasonic sensors, a Blynk app for IoT communication, and a local alert system with a buzzer, this system presents an innovative solution for efficient waste monitoring and management. The core functionality of the system revolves around the ESP32 microcontroller, a versatile and powerful device that acts as the brain of the waste management system. Integrated with ultrasonic sensors, the ESP32 enables real-time monitoring of waste levels in designated bins. This data is crucial for optimizing waste collection routes and schedules. The Blynk app serves as the user interface, allowing city administrators and waste management personnel to remotely monitor the waste levels, receive alerts, and manage the waste collection process efficiently. The integration of IoT technology through the Blynk app ensures real-time communication and data accessibility. Local alerts are incorporated into the system using a buzzer, providing immediate notification to on-site personnel when a waste bin reaches a predefined threshold. This local alert mechanism ensures timely response and prevents overflowing, contributing to a cleaner and more organized urban environment. The project's theoretical framework emphasizes the integration of IoT, sensor technology, and local alert mechanisms to create a smart and responsive waste management system. The real-time data provided by the ESP32 and ultrasonic sensors, coupled with the convenience of the Blynk app, offers a holistic approach to waste monitoring and collection. The "Solid Waste Management System for Smart Cities" represents a paradigm shift in waste management practices, providing a technologically advanced and efficient solution for urban areas. By harnessing the capabilities of ESP32, ultrasonic sensors, and IoT communication, this project contributes to the creation of cleaner, more sustainable, and smarter cities.

**Keywords-** Smart Cities, Iot Module, Arduino Nano MCU, OLED Display,.

### 1. INTRODUCTION

Waste management has emerged as a pressing concern in contemporary urban settings, with the daily accumulation of waste reaching unprecedented levels. Maintaining a clean, healthy, and sustainable living environment hinges on the implementation of effective waste management practices. However, conventional approaches to waste management predominantly rely on manual monitoring and collection processes, characterized by inefficiency, time consumption, and resource depletion. Recognizing the imperative for innovation, the integration of technology offers a promising avenue to revolutionize waste management systems, enhancing their efficiency and efficacy. This paper presents a groundbreaking Solid Waste Management System designed specifically for Smart Cities, harnessing the capabilities of cutting-edge technologies to address the challenges of waste management comprehensively. Central to this system is the ESP32 microcontroller, renowned for its versatility and computational prowess, serving as the backbone of the waste management infrastructure. Complementing the ESP32 are ultrasonic sensors, strategically deployed to monitor waste levels in collection bins and optimize collection routes. The integration of IoT communication through the Blynk app facilitates real-time monitoring and management of waste collection operations, enabling seamless coordination between stakeholders and enhancing overall system responsiveness. Furthermore, a local alert system featuring a buzzer provides immediate notification of critical events, such as bin overflow or malfunction, ensuring timely intervention and resolution. By leveraging advanced technologies, the proposed Solid Waste Management System for Smart Cities aims to revolutionize traditional waste management practices, offering numerous benefits. These include enhanced operational efficiency, optimized resource utilization, and reduced environmental impact. Moreover, the system's scalability and adaptability make it well-suited for deployment in diverse urban environments, catering to varying waste management needs and infrastructural constraints. The adoption of this technologically advanced waste management solution promises to usher in a new era of sustainability and cleanliness in Smart Cities, paving the way for healthier and more livable urban spaces. Through the convergence of innovation and environmental stewardship, this paper contributes to the ongoing discourse on smart urban development and underscores the pivotal role of technology in shaping the cities of the future. [1-3]

## 2. LITERATURE REVIEW

Several studies have explored the potential of technology in waste management. Kulkarni et al. [1] proposed an IoT-based waste management system using ESP8266 and ultrasonic sensors. The system enables real-time monitoring of waste levels in bins and optimizes waste collection routes. Similarly, Choi et al. [2] developed a smart waste management system using wireless sensors and cloud computing. The system provides real-time data on waste levels, reducing collection frequency and operational costs. Other studies have also explored the potential of IoT in waste management [3][4]. However, these studies do not emphasize the integration of local alert mechanisms with IoT communication for timely response.[6-7]

### HARDWARE AND SOFTWARE

The block diagram of the Solid Waste Management System for Smart Cities is shown in Figure 1. The ESP32 microcontroller acts as the central processing unit, interfacing with the ultrasonic sensors and the Blynk app for IoT communication. The local alert system with a buzzer is integrated into the ESP32 microcontroller, providing immediate notification to on-site personnel when necessary.

The block diagram of the system is shown in figure-1

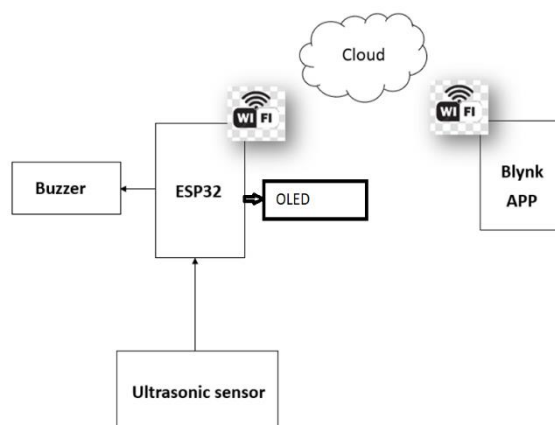

Figure :- Block Diagram of Solid wastage management system for smart cities

The block diagram of the system is shown in figure-1

#### A. ESP 32 MCU

The ESP32 is a highly versatile System on a Chip (SoC) microcontroller developed by Espressif Systems, renowned for its widespread adoption in various applications such as wireless communication, IoT devices, home automation, robotics, and embedded systems. With its low cost and multifunctionality, it has become a preferred choice for developers seeking to implement cutting-edge technologies in their projects. Programmed primarily in C/C++ using the Arduino programming language, the ESP32 offers ease of development and compatibility with existing Arduino libraries and tools. Developed by Espressif Systems, a Chinese company headquartered in Shanghai, the ESP32 is manufactured by TSMC using their 40 nm process, ensuring high quality and reliability. Serving as a successor to the ESP8266 microcontroller, the ESP32, specifically the ESP-WROOM-32 module featuring the ESP32-D0WDQ6 chip, boasts integrated Wi-Fi and dual-mode Bluetooth capabilities. The ESP32 series encompasses a range of low-cost, low-power microcontrollers, designed to meet the demands of modern technology applications. Its integrated Wi-Fi and Bluetooth functionalities make it particularly well-suited for mobile devices, wearable technology, and IoT applications. Overall, the ESP32 stands as a testament to the advancements in microcontroller technology, offering developers a powerful and versatile platform to bring their innovative ideas to life. Figure-2 shows the ESP32 MCU



Figure-2 shows the Arduino nano MCU

### B. ULTRASONIC SENSOR:

An ultrasonic sensor is a device utilized to measure the distance to an object by emitting and receiving ultrasonic sound waves. It operates by employing a transducer that emits ultrasonic pulses and detects their reflection to gather information about an object's proximity. These sensors possess the capability to measure distances to a wide range of objects, regardless of their shape, color, or surface texture, making them versatile in various applications. Additionally, ultrasonic sensors can detect both approaching and receding objects, enhancing their utility in proximity detection systems. There are several types of ultrasonic sensors, including through-beam sensors, proximity switches, and retro-reflective sensors, each catering to specific application requirements. The development of ultrasonic sensor technology dates back to the early 20th century, with patents obtained for utilizing ultrasonic waves in detecting flaws in solids. Over time, advancements such as pulsed ultrasonic testing techniques have further refined the capabilities of these sensors. Furthermore, the frequency of ultrasonic sensors plays a crucial role in determining their range, with low-frequency sensors typically offering longer ranges compared to high-frequency ones due to the longer waves they produce. For instance, a 40 kHz ultrasonic sensor may have a range of up to 4 meters, while a 200 kHz sensor may only reach up to 1 meter.. Figure-3 shows ultrasonic sensor pin out.

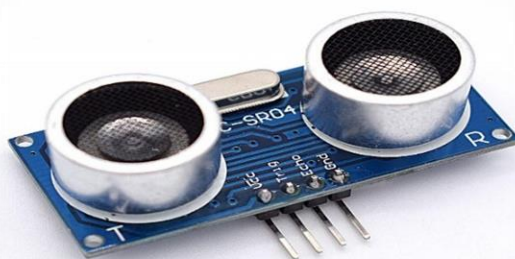

Figure-3 shows ultrasonic sensor pin out.

### C. OLED display

The OLED display is a compact 128x64 pixel screen known for its ability to provide clear visual feedback, showcasing messages such as "full " or "System Initializing." Operating with low power consumption, it boasts high contrast and brightness, ensuring readability in various lighting conditions. With communication options including I2C or SPI interfaces, it offers flexibility in integration with different systems. While its dimensions may vary depending on the model, they are typically compact, making it ideal for embedded applications. Supporting a variety of fonts and graphics, the OLED display enhances user interface design, contributing to an improved user experience. With a resolution of 128x64 pixels, it delivers crisp and detailed display quality, suitable for showcasing real-time data, status updates, and notifications in embedded systems. Overall, its versatility makes it a valuable component for enhancing the functionality and user interaction of various electronic devices. Figure-4 shows the OLED pin diagram.

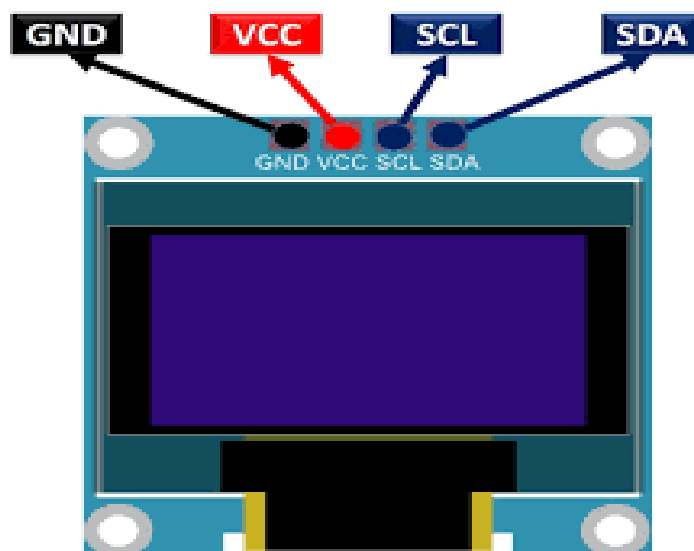

Figure-4 shows the OLED pin diagram

#### D. Buzzer :

The buzzer is an audio output device that emits an audible alert in response to fall events, enhancing the system's notification capabilities. It operates on a specified voltage range and produces sound at a defined frequency. Figure-5 shows the pinout of Buzzer.

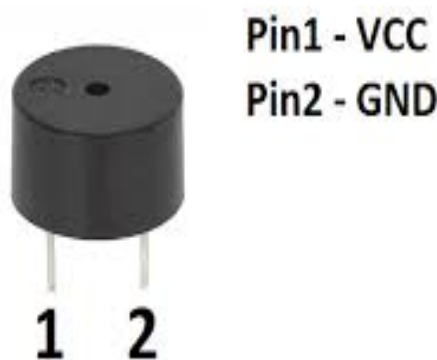

Figure-5 shows the pinout of Buzzer.

#### E. Power supply

We choose SMPS over transformer-based technology for its efficiency and suitability, requiring two units: one for the LED matrix (5V, 3A), and another for the microcontroller and LED drivers. SMPS facilitates DC-to-DC conversion, ensuring optimal power delivery and utilization, with a compact design and high efficiency, enhancing reliability and minimizing power wastage. This aligns with our project's goals of efficiency and sustainability.

#### F. Arduino IDE and C++

Arduino IDE and C++ form an indispensable duo for crafting embedded systems and IoT projects, furnishing developers with an intuitive platform for code creation, compilation, and deployment onto Arduino boards. As the primary programming language in Arduino development, C++ stands out for its versatility and efficiency. Through Arduino IDE's user-friendly interface, hardware components are effortlessly interfaced using straightforward syntax, while C++ empowers developers with its object-oriented capabilities, fostering the development of modular and reusable code structures. Simplifying intricate tasks, Arduino IDE's vast library ecosystem harmonizes with C++'s robust features, enhancing code organization and maintainability. Real-time debugging and data visualization are facilitated by the integrated serial monitor, while C++'s efficiency maximizes code execution on microcontrollers. Furthermore, Arduino IDE's cross-platform compatibility ensures seamless development across diverse operating systems. In essence, Arduino IDE and C++ jointly furnish developers with a potent toolkit for constructing embedded systems and IoT applications, characterized by simplicity, adaptability, and efficiency.

#### G. Blynk App

The Blynk app stands as a versatile platform designed for controlling Arduino, Raspberry Pi, and similar devices remotely over the internet, offering iOS and Android compatibility. Developed with the Internet of Things (IoT) in mind, it empowers users to oversee hardware operations from anywhere, display sensor data, store information, visualize data, and execute a myriad of other functions. With a focus on ease of use, the app caters to both businesses and developers seeking streamlined IoT solutions. At the heart of the Blynk ecosystem lies its server, responsible for facilitating seamless communication between smartphones and connected hardware devices. Users have the option to utilize the Blynk Cloud or deploy their private Blynk server locally, leveraging its open-source nature and scalability to accommodate numerous devices. Notably, the Blynk app operates in conjunction with Blynk Libraries, ensuring smooth integration and functionality within the IoT ecosystem. With support for various connectivity options including Ethernet, Wi-Fi, Bluetooth LE, Serial Port, and 3G, the app offers flexibility to accommodate diverse hardware configurations. It serves as a vital tool for businesses and individuals seeking to harness the power of IoT for smart home automation, industrial monitoring, environmental sensing, and beyond. Overall, the Blynk app stands as a testament to the transformative potential of IoT technology, enabling users to seamlessly connect and control their devices from anywhere in the world with ease and convenience.

### 3. RESULTS AND DISCUSSION

The Solid Waste Management System for Smart Cities, as outlined in this paper, presents a pioneering approach to address the challenges of waste management in urban environments. By leveraging cutting-edge technologies such as the ESP32 microcontroller, ultrasonic sensors, the Blynk app for IoT communication, and a local alert system with a buzzer, this system offers an innovative solution for efficient waste monitoring and management. The integration of



these technologies enables real-time monitoring of waste levels in designated bins, facilitating optimization of waste collection routes and schedules. Moreover, the Blynk app serves as a user-friendly interface, enabling city administrators and waste management personnel to remotely monitor waste levels, receive alerts, and manage the waste collection process efficiently. The incorporation of IoT technology through the Blynk app ensures real-time communication and data accessibility, further enhancing the system's responsiveness and efficiency. Additionally, the inclusion of a local alert system with a buzzer provides immediate notification to on-site personnel when a waste bin reaches a predefined threshold, enabling timely intervention and preventing overflowing. In terms of hardware components, the ESP32 microcontroller acts as the central processing unit, interfacing with ultrasonic sensors and the Blynk app for IoT communication. The ultrasonic sensors play a crucial role in monitoring waste levels in collection bins, while the OLED display provides visual feedback to users, enhancing the user experience. Furthermore, the buzzer serves as a local alert mechanism, ensuring prompt response to critical events.

The theoretical framework of the project emphasizes the integration of IoT, sensor technology, and local alert mechanisms to create a smart and responsive waste management system. The real-time data provided by the ESP32 and ultrasonic sensors, coupled with the convenience of the Blynk app, offers a holistic approach to waste monitoring and collection. The results and discussion section of this paper will focus on evaluating the effectiveness and performance of the Solid Waste Management System for Smart Cities in real-world scenarios. This will involve assessing factors such as system reliability, accuracy of waste level monitoring, responsiveness to alerts, and overall efficiency in waste management operations. Additionally, the scalability and adaptability of the system will be explored, considering its potential for deployment in diverse urban environments. Through comprehensive analysis and evaluation, insights will be gained into the practical implications and benefits of adopting such a technologically advanced waste management solution. Figure-6 and 7 shows the working models of the systems.

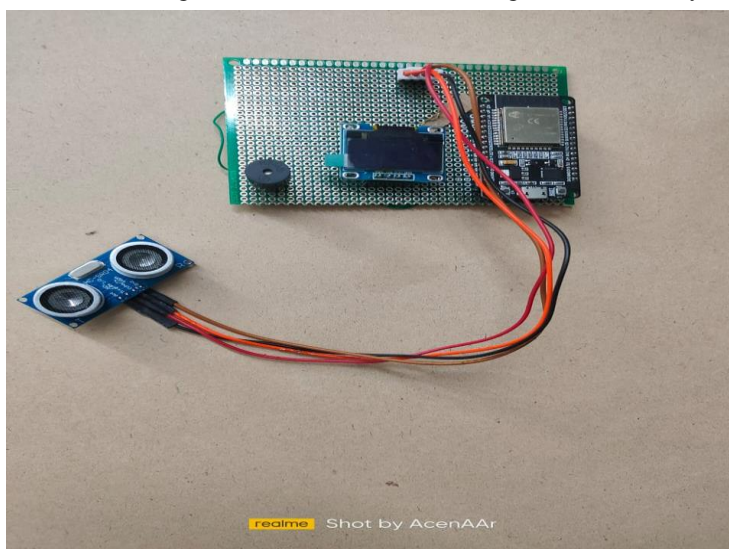

Figure-6 working model-1



Figure-7 working model-2

#### 4. CONCLUSION

The Person/Wheelchair Fall Detection and Alert System is a reliable and non-invasive solution for monitoring vulnerable individuals, ensuring their safety and security. The system's real-time fall detection and alert capabilities make it an essential tool for enhancing the quality of life for elderly or physically impaired individuals.

#### 5. FUTURE WORK

The Solid Waste Management System for Smart Cities lays a foundation for future advancements and enhancements in waste management technology. Potential avenues for future development include the integration of machine learning algorithms for predictive waste monitoring, incorporation of renewable energy sources for sustainable operation, implementation of advanced sensor technologies for more accurate data collection, exploration of robotic systems for automated waste collection, and expansion of the system's capabilities to include additional environmental monitoring functions. Furthermore, collaboration with local governments and urban planners can facilitate the implementation of city-wide waste management initiatives, while partnerships with industry stakeholders can drive innovation and scalability. Overall, the future scope of the Solid Waste Management System for Smart Cities encompasses a broad range of possibilities aimed at further improving efficiency, sustainability, and effectiveness in urban waste management practices..

#### 6. REFERENCES

- [1] Kulkarni, S., Kulkarni, S., & Raut, R. (2019). IoT based waste management system using ESP8266 and ultrasonic sensor. *International Journal of Scientific Research in Computer Science, Engineering and Information Technology*, 4(5), 25-30.
- [2] Choi, J., Kim, J., Lee, J., & Park, Y. (2018). Smart waste management system using wireless sensor network and cloud computing. *Sensors*, 18(10), 3369.
- [3] Al-Abbadi, L. S., Al-Maitah, M. N., & Zawaideh, M. A. (2019). Internet of Things (IoT) in waste management: A systematic review. *Jordanian Journal of Computers and Information Technology*, 5(3), 187-206.
- [4] Kim, H. K., Lee, Y., Kim, H., & Kim, S. (2019). Development of IoT-based waste management system in Korea. *Sustainability*, 11(16), 4495.
- [5] Wei, L., & Zhao, L. (2020). Design of waste bin monitoring system based on Internet of things. *IOP Conference Series: Earth and Environmental Science*, 465(2), 022043.
- [6] Al-Qaysi, N. H., Al-Badi, A. H., & Mohammed, N. F. (2017). IoT based smart waste management system. *International Journal of Advanced Computer Science and Applications*, 8(5), 164-171.
- [7] Thakur, S., & Bhandari, A. (2021). Smart waste management system for sustainable environment using Internet of Things. *Journal of Renewable Energy and Environment Engineering*, 9(2), 1-8.