

DESIGN AND DEVELOPMENT OF AGRICULTURAL SOLID FERTILIZER SPREADER VEHICLE

Satyajit Pardeshi¹, Vishavjeet Patil², Yash Patil³, Vedant Swami⁴, Kedar Kanase⁵
Rahul Gaji⁶

^{1,2,3,4,5,6}Department Of Mechanical Engineering Annasaheb Dange College Of Engineering & Technology,
Ashta, Dist: Sangli, Maharashtra, India.

DOI: <https://www.doi.org/10.58257/IJPREMS33294>

ABSTRACT

The background of the agricultural project lies in the context of the Indian economy, where agriculture plays a crucial role. Traditional farming methods, particularly manual fertilization practices, have faced challenges in meeting the demands for increased crop production. Studies indicate inefficiencies in the conventional approach, prompting the need for innovative solutions. The project specifically addresses the limitations of manual fertilization by introducing an automated system. The decision to develop this solution arises from a recognition of the importance of enhancing agricultural productivity, reducing labor-intensive tasks, and embracing technology to modernize farming practices.

Keywords: Chassis, Agriculture, Multipurpose Components, Robotics, CATIA Design, Agricultural machine.

1. INTRODUCTION

In traditional Indian agriculture, manual fertilization methods have proven to be inefficient and labor-intensive, leading to sub optimal crop yields. The existing practices are unable to meet the increasing demands for agricultural productivity. The need for a more effective and automated fertilization system is evident to address these challenges and enhance overall crop production. The project aims to design and implement a solution that automates the fertilization process, ensuring precise and consistent distribution of fertilizers to improve efficiency, reduce labor strain, and contribute to the modernization of Indian agriculture. While harvesting the crop, farmer take the crop and put in bucket, once the bucket is full farmer must move to the collection point and empty the bucket. Farmer again returns to the same location and start Harvesting. Due to this repetition, the person gets fatigued.

2. METHODOLOGY

2.1 Design and Analysis: In this phase, the

- The concept drawing of the vehicle will be drawn.
- The major components of the vehicle will be listed, their weight will be noted from the specification sheet.
- The design of the vehicle will be done considering the weight to solid fertilizer is i.e., 10 kg, weight.
- The drawing of the model would be done in CATIA or suitable software.
- he suitable analytical and numerical method will be used while designing the system

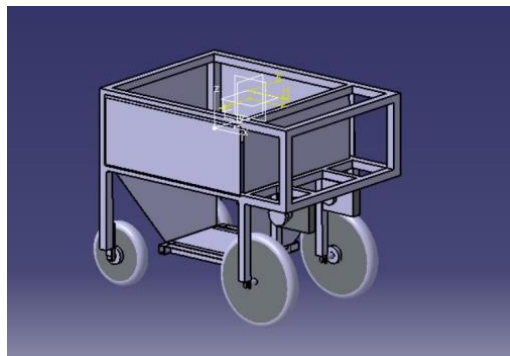

Model Design in CATIA (proposed)

2.2 Preparation of Manufacturing Drawing:

In this phase, the design will be finalized, and assembly and detailed drawing, bill of material will be done on suitable software. Automatic human following system will designed and dry run test will be carried out in laboratory in this phase. Manufacturing of Component and Working Model:

2.3 Performance Testing:

Performance testing of the model will be done in suitable agricultural land. The testing will be done by varying person etc. The testing will ensure completion of objectives mentioned.

3. MODELING AND ANALYSIS

3.1 Manual control

For manually control, we use Bluetooth control module so we can control the vehicle from mobile device. So, it can be easy to control.

In manual control, we use the Bluetooth module, so we download Arduino Bluetooth controller app from play store, and it is support only android 12 and there below version and install in smartphone.

1-Start of vehicle

After connecting the Mobile Device to the Arduino controller. For starting the vehicle, we need to press the start button on the mobile device. As shown in figure 35.



Start of vehicle

2-Stop of vehicle

To stop the vehicle, we need to press the select button (As shown in the figure 36) on the mobile device.



Stop of vehicle

3-Forward direction

To move vehicle in forward direction we need to press forward (triangle) button in mobile phone (as shown in figure 37).

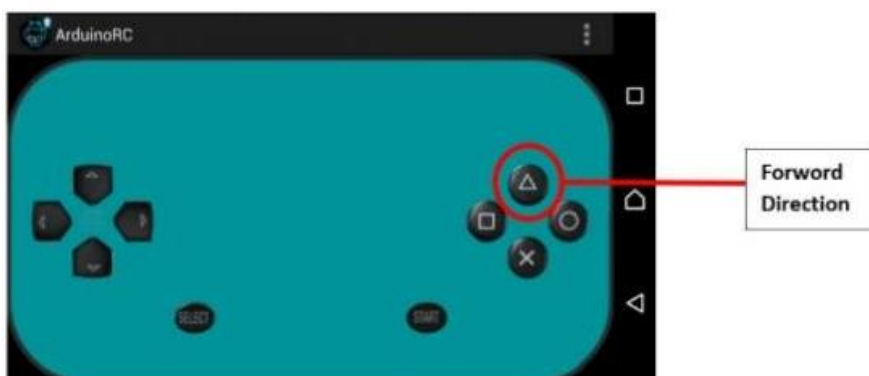

Forward direction

4-Reverse direction

To move vehicle in reverse direction we need to press Reverse (Cross) button in mobile phone. (as shown in figure 38).



Reverse direction

5-Right turn

To move the vehicle in the right direction we need to press the rectangle button (as shown in the figure 39). then the vehicle's left sides two wheels move in the forward direction and the right two wheels move in the reverse direction. Then the vehicle moves in the right direction.



Right turn of Vehicle

6- Left turn of vehicle

To move the vehicle in the left direction we need to press the circle button (as shown in the figure 40). then the vehicle's right sides two wheels move in the forward direction and the left two wheels move in the reverse direction. Then the vehicle moves in the left direction.



Left turn of vehicle

3.2 Testing

After the assembly and all the programming done. We take the test of Agriculture load carrier vehicle in the farm; in that we observed the working of our project. For the testing, we used standard weights to apply load on the vehicle. In the testing, we increased load on vehicle in that the vehicle is working. So, in that different weight the vehicle is automatically follow the person and work manually by Bluetooth module. In table 12 we show the testing reading on different weight.

3.3 Testing

Weight (Kg)	Status
2	Yes
4	Yes
6	Yes
8	Yes
10	Yes



Photograph of Testing in farm



Testing 6kg load (Bluetooth control)

4. RESULTS AND DISCUSSION

Results indicate the innovative fertilization project enhances efficiency, productivity, and environmental sustainability in Indian agriculture. Automated distribution improves nutrient coverage, reducing labor and input costs. Challenges in adoption persist, but supportive policies and awareness efforts are underway. The project promises to modernize farming practices and improve livelihoods.

5. CONCLUSIONS

- The innovative fertilization project demonstrates significant potential for enhancing efficiency and productivity in Indian agriculture.
- Automated distribution improves nutrient coverage, reducing labor and input costs.
- Adoption challenges remain, but supportive policies and awareness efforts are underway.
- Overall, the project promises to modernize farming practices and improve livelihoods in the agricultural sector.

6. REFERENCES

- [1] J. Wawerla, And Richard T. Vaughan, "A fast and frugal method for team task allocation in a multi-robot transportation system," in Proceedings of the 2010 IEEE International Conference on Robotics and Automation (ICRA'10), Anchorage, AK, USA, May 2010, PP. 1432–1437.
- [2] Keisuke TOMIO, Hiroya IGARASHI, And Akira HARADA, "Designing of a Carrier Robot "CARREY" at Office," 6th Asian Design Conference Vol.1 Japan, 2003.
- [3] F. Tang and L. E. Parker, "ASyMTRe: Automated synthesis of multi-robot task solutions through software reconfiguration," in Proceedings of the 2005 IEEE International Conference on Robotics and Automation (ICRA'05), Barcelona, Spain, April 2005, PP. 1501–1508.
- [4] P. Kamal And Upputuri Hari Babu, "INTELLIGENT GOODS CARRIER ROBOT," International Journal of Creative Research Thoughts (IJCRT), Volume 9, Issue 1, pp. 2925-2926, January 2021.
- [5] R. Alami, "Multi-robot cooperation in the MARTHA project", IEEE Robotics and Automation Magazine, vol. 5, no. 1, pp. 36–47, March 1998.
- [6] Roldan J.J, Jaime del cerro, David Gerzon ramos and Mario garzon, "Robots in agriculture: State of art and practical experiences", In Service Robots; IntechOpen: London, UK, 2017.
- [7] P.J. Grimstad, "Raspberry—Robotic and Autonomous Systems for Berry Production". ASME Mech. Eng. 2018, 140, PP-14–18.