

CLIMATE CLOCK

Ahire Sarika¹, Kapadnis Prerana², Shinde Udayan³

^{1,2,3}Student, Department of E&TC, MVP'S KBT College of Engineering, Nashik, Maharashtra, India.

ABSTRACT

Global Warming is the gradational increase in the average face temperature of the Earth. The Climate Clock uses an LED matrix display to show the time left before the Earth reaches a certain global warming temperature. The remaining time is determined by two factors the carbon budget needed to reach a given global warming temperature and the current rate of CO₂ emigration. The budget for limiting global warming to 1.5 degrees is 280 billion tons, while the current periodic rate of CO₂ emigration is roughly 43 billion tons. Dividing the first number by the alternate number gives us the time left until we reach 1.5 degrees of global warming. The time left is around 5.6 times, which is dwindling every second. The Climate timepiece displays this preamble.

Keywords: Wired display boards, Wi-Fi, LED Matrix Display, Wireless Technology

1. INTRODUCTION

In 2018, the Intergovernmental Panel on Climate Change released a Special Report which aimed to quantify the remaining global carbon budget that could potentially keep global warming below 1.5°C. Recently, in summer 2021, the IPCC published another report on the physical science basis of climate change, which contained updated carbon budget estimates for limiting global warming to 1.5°C. According to this report, the researchers estimated that humans could release an additional 400Gt of carbon into the atmosphere starting from 2020 and still have a 67% chance of limiting warming to 1.5°C.

2. RELATED WORK

The data for the Climate Clock deadline comes from the Mercator Research Institute on Global Commons and Climate Change. The MCC's carbon clock assumes an average annual rate of 42.2 Gt of carbon emissions to calculate the remaining time on the clock. However, if global emissions continue to rise, our carbon budget will run out even faster. On the other hand, if we can cut the rate of global carbon emissions, the remaining time on the clock would hypothetically begin to increase. This system takes ideas from other system which have already been implemented earlier. It merges two different project ideas into single unit. It is an extended version of already existing LED scrolling display board. But here we are using timer count in reverse order technology using HD-2020 Software app through Wi-Fi module. For making this LED display more portable, HD-2020 Software is used instead of carrying a computer or keyboard every time the data is updated automatically by the app which is to be displayed on the LED matrix display. A Wi-Fi module which is a driver is connected to the LED display hardware and is used to receive the timer count and send it to the controller circuit of LED display. Then the controller circuitry which drive the led matrix stores the received data in externally interfaced RAM and compare the same with lookup table stored in controller program displays the timer count on LED display board through app, from any desired location in the country. This idea used in this project is to minimize the cost that is required in the traditional LED display board and makes easier to send data to those LED display boards. The project uses a Wi-Fi at the display side to receive the text signal. Along with this, Switch mode power supplies are used for controlling led driver and led matrix.

2.1 CAUSES- The Climate Clock deadline is a representation of the time we have left until this carbon budget runs out, which is based on the amount of carbon we continue to emit globally. Reason for temperature reaching 1.5°C are shown below:

2.1.1 Floods:-

Frequency Extreme Event	1970-1979	2010-2019
Floods	313	1393

2.1.2 Forest Fires:

Frequency Extreme Event	1970-1979	2010-2019
Forest fires	28	127

2.1.3 Storms:-

Frequency Extreme Event	1970-1979	2010-2019
Storms	249	1108

2.1.4 Sea Level Rise:-

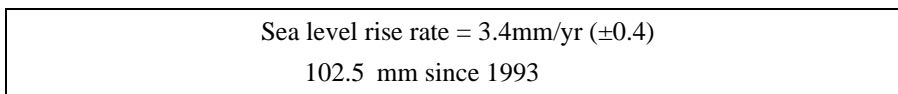

1.1.5 Average Global Surface Temperature (1880-2020):-

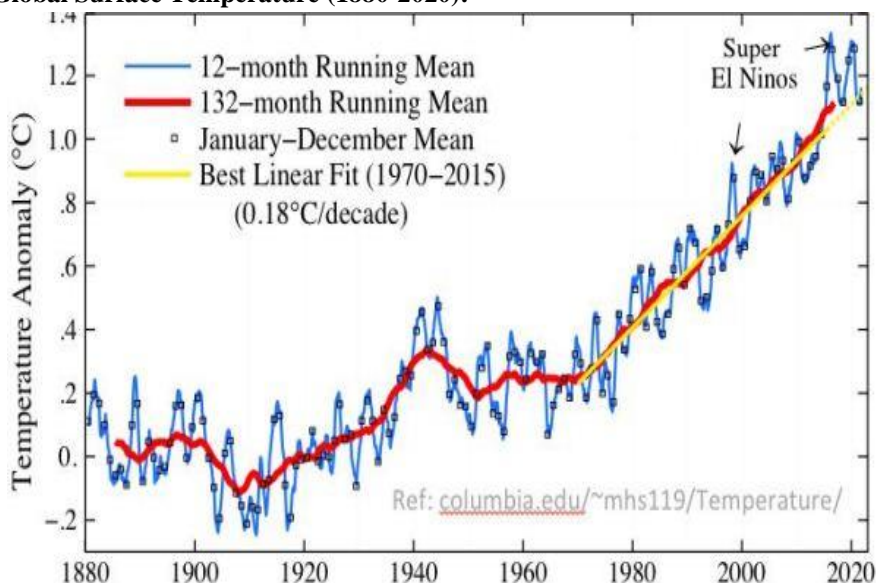

Figure 1 : Raising Temperature Graph

3. METHODOLOGY

The Project mainly consists of 5 major components:

1. Power Supply
2. SMPS
3. HD-WF1 Controller
4. Led Matrix Display
5. HD-2020 Software

This proposed system allows people to directly check the left time to reached to 1.5 degree Temperature. Here ,we used the wireless WIFI technology for communication .230V AC power supply is given to the 12V SMPS device which converts AC into DC .SMPS gives power to the controller and LED matrix display. Basically Controller (HD-WF1) is used to control the LED matrix display it receive control signal from the HD 2020 software.

3.1 BLOCK DIAGRAM:

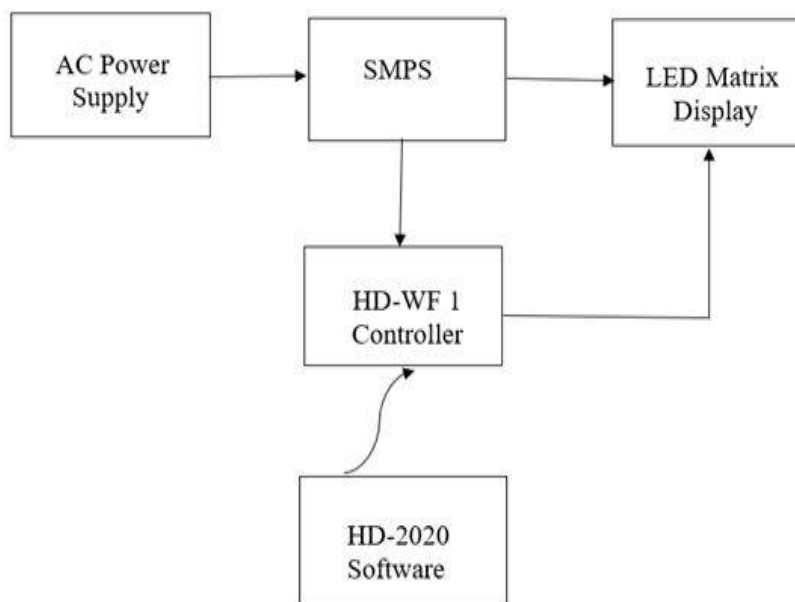

Figure 2: Block Diagram

3.2 FLOW CHART:

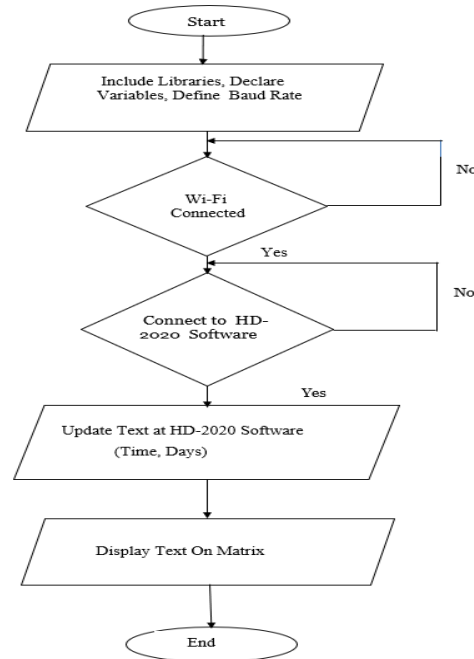

Figure 3: Flow Chart

4. RESULT

After Completing and Testing the project we have observe the following result. As shown below.



Figure 4: Result

5. CONCLUSION

In conclusion, the climate clock project serves as a powerful reminder of the urgent need to address the climate change. As the clock ticks, it determines that the finite period of time we have to take meaningful action and reduce our carbon emissions to prevent the hazardous consequences, we would be facing in future. The conclusion of this project tells us the importance of collective efforts, from individuals to governments and businesses, of converting from fossil practices to sustainable practices adopting renewable energy sources, and implementing policies that prioritize the health of our planet. It's called to action, reminder that time is running out, but we also have opportunity, that we can still make positive impact on our environment and future generations

6. REFERENCES

- [1] Beyerle G,Schmidt T, Wickert J, Heise S, Rothacher M,Konig-Langlo G, Lauritsen K (2006) Observations and simulation of receiver-induced refractivity biases in GPS radio occultation. J Geophys Res 111(D12101), doi: 10.1029/2005JD006673
- [2] Wilson JJW,Luntama JP (2007) Advanced processing algorithms for GRAS instruments data.In: Geosciences and remoting sensing Symposium,IGARSS 2007,IEEE International, Barcelon, Spain,pp 1049-1054,doi:10.1109/IGRASS.2007.4422981
- [3] [Bhattaacharyya A,Yeh KC,Franke SJ (1992) Deducing turbulence parameters from transionospheric scintillation measurements. Space sci Rav 61 (3-4):335-386
- [4] Loscher A, Retscher C,Fusco L,Goncalves P, Brito F,Kirchengast G(2008) Variational optimization for global climate analysis on ESA`shigh performance computing grid. Remoting Sensing of Environments, Special issues: Remote Sensing Data Assimilation 112:1450-1463,doi:10.1016/j.rse.2007.05.022