

BLUETOOTH CONTROLLED ROBOT CAR USING ARDUINO

Dr. M. Saravanan¹, K. Varun paul², K. Raju³, A. Shiva⁴, K. Shiva Kumar⁵

¹Professor, EEE, Holy Mary Institute of Technology & Science, Bogaram, Telangana, India.

^{2,3,4,5}Student, EEE, Holy Mary Institute of Technology & Science, Bogaram, Telangana, India.

ABSTRACT

In the past few months Bluetooth technology is increasing dramatically with improving of Bluetooth phones and other electronics items in our daily life. To meet current requirements of several needs the technology is already increased with help of remote- controlled robotic cars via Bluetooth. So here open-source hardware is used to designed and also developed a robotic controlled car with the help of simple architecture. To move a certain direction of our proposed design pre-installed command is used. In this paper android application running on a Smartphone has been developed with the help of user. This proposed design helps to control the motion of the car remotely with the help of Bluetooth kept feasible manner. Arduino act as main part of the device which is controlled with the help of our Smartphone via Bluetooth. So here Bluetooth act as a main communicator between several controllers and our Smartphone using protocols.

Keywords: Bluetooth Module, Bluetooth controlled Robot Car, Arduino, Android Phone, Robot.

1. INTRODUCTION

In the recent days, the process of being developing is drastically improved, particularly increased in the communication fields such as Bluetooth, other remote-controlled cars and robots. In every country technology is currently developing with many users, especially in India every people are using different operating systems which are available in several smart phones. In olden days the communication between devices should be transmitted in wired and risky way without seeking any help of any person. But in present world the communication between devices is improved in wireless manner without risk and fast are kept feasible manner with taking help of persons. Android operating system is used to communicate between Smartphone hardware and several mobile applications. This designed model is controlled with the help of Bluetooth using Smartphone. This robot is shaped like a car structure which contains of four wheels. This proposed designed is mainly used in different areas and fields in many industries Such as travelling goods from one place to another place and also moving many tiny particles in a fast manner. Arduino Uno is act as main controller of the device which controls Dc motors to move several directions. This model can control with two main devices. One device is computer and another device is our Smartphone. In many countries using of wheeled controlled robot cars are improved with increasing several industrial profits. To improve the performance of wheeled robots there are many developments available in all areas of life to develop in the world. All researchers are investigated the designed model extensively with the help remote.

2. WORKING PRINCIPLE

The operating of the robot-controlled car is very easy and freely available everywhere in the world. To activate Motors and motor drivers here two 9 voltage power(18volts) is supplied. Bluetooth Rc car app is installed in Smart phone which helps to controls the robot car, motors and motor drivers which moves robot car in several places Bluetooth Rc car app has different common keys to move the robot different directions with the help of Smartphone. Bluetooth Rc car app is used to send the signals and to receive signals in between Smartphone and Arduino hardware. Here Arduino acts as main controller of the device which receives signal or commands and sends these commands to motors and motor drivers to perform a particular task. Robot controlled car made up of 2 motors and 1 motor driver which move the car in 4 directions, So here Arduino controls whole system. These all components are attached to robot chassis. To code the Arduino Ide (Arduino) software is used. Arduino is associated to computer or laptop using data cable to upload the code and once coding is uploaded then I remove the cable. These commands or instructions will transfer the data or information to the Arduino to communicate with the remote (Smartphone) In the upper figure represents two Bluetooth RC controller application interfaces. Every user can operate this robot car easily without train the controlling. First picture indicates that after open the application in the Smartphone. User can turn on Bluetooth in both Car and Smartphone to connect the device. After turn on the Bluetooth searching for available devices that means scanning. If the device is detected then the device is connected to app. In case the device is not detected then wait for searching devices. Second picture indicates that buttons to control the robot car. So here app has 4 buttons to move 4 directions. Arrow up button and down button is used to move the robot car front and downward directions and another two buttons is used to move the robot car right and left directions. Each and every button will be subjected to each operation to handle the robot car easily. These buttons are easy to use to operate freely when compared to every project in the world.

3. FLOW CHART

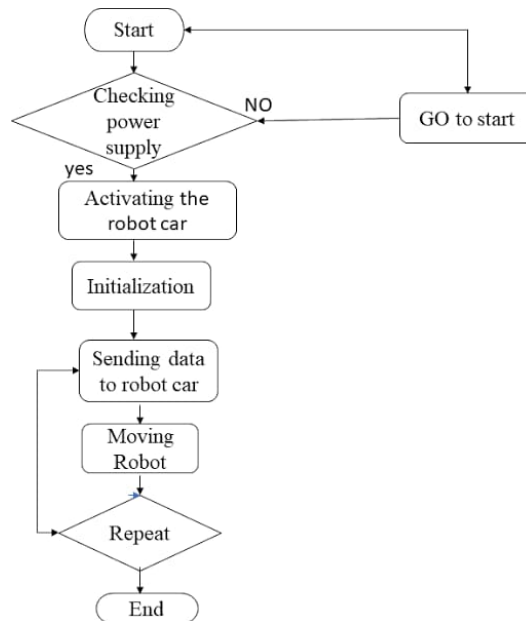

Figure1. Flow chart

4. HAED REQUIREMENTS

1. Arduino UNO
2. Motor Diver L293D

4.1 ARDUINO UNO

Arduino name came from a bar in Ivrea which is located in Italy. Uno means one number in Italian language. Massimo Banzi was created Arduino Uno and Hernando Barragan was developed and added the support of microcontroller(atmega16) to wiring in 2003.It is easy to use and freely available in market with less cost. It also has a function that every user can develop without any problem. Arduino IDE software is used to handle this designed board easily with flexible manner. It is designed for to create engineering project and introduced in 2008 in the world. It consists of microcontroller (At mega 328p) to program the Arduino board using Arduino IDE software. It has a capacity to operate the output voltage 3.3 to 5v without any disturbances. Uno receive the voltage 7volts to 20volts as an input voltage.6 analog (pulse width modulation) pins and 14 digital pins is used to write and read the functions in the Arduino board. So here to transmit the serial data from Arduino board to projects Tx pin is used and also Rx pin is used to receive the serial data from project to Arduino board. Here mainly Arduino Uno board is used to control the overall designed model including each and every part.

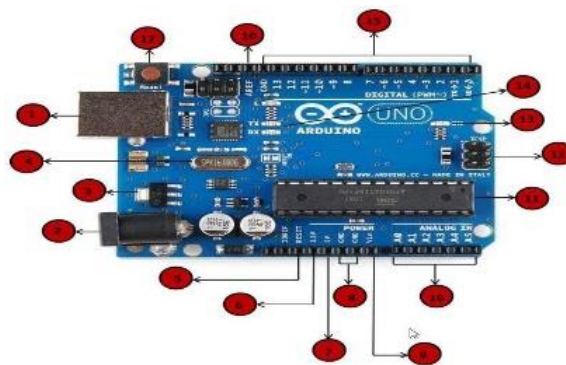

Figure2. Arduino UNO

4.2 MOTOR DRIVER L293D

To control two dc motors at the same time here two H-Ground motors is used which gives permissions to DC motors. L293d has H- bridge module which allows to control every direction of dc motors and speed. Here enables line is used to turn on and turn off the speed of all motors and motor drivers. It has 4 output pins and 4 input pins to control the motors independently and easily without any interruptions. Here TTL logic levels is designed to undertake heavy loads. L293d motor driver can handle the voltages from 5volts to 35volts easily and freely. To run the DC motors in any voltages motor driver can help to motors to convert low voltages to high voltages without any disturbances.

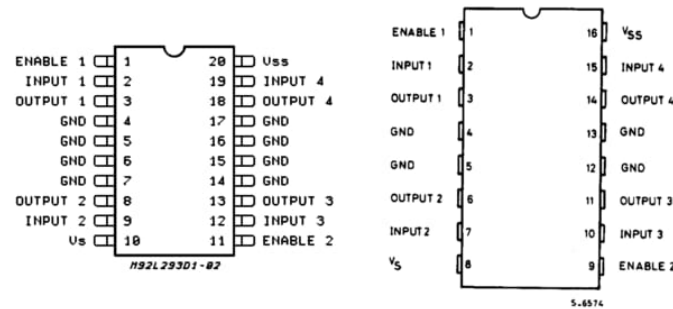

Figure3. Motor Driver L293D

5. SOFTWARE REQUIREMENTS

5.1. BLUETOOTH RC CAR/ARDUINO IDE

It is designed for to control small type of robot car easily and also designed for small type of Iot devices ecofriendly. To store the data and to perform many several tasks this software application is used and also it helps very eco-friendly. To download this RC car application, it is freely available in Google Play store and Apple Appstore easily. To communicate with this designed model Bluetooth RC car application provides understandable interfaces to each and every user. This application is very fast to communicate with our designed model when compared to other applications and also it helpful to develop this designed model in quick manner.

5.2. ARDUINO SOFTWARE

Micro controller is present in the Arduino pcb board which is used to communicate with this designed model easily and it is also used to control the whole Arduino board with flexible manner. To burnt the code in microcontroller IDE software is used. So here these coded instructions will be stored in EEPROM with the help of Arduino IDE software.

5.3. HC-05 BLUETOOTH MODULE:

In 1994 started developing and designing of this board up to 1997 with a workable solution. Nils Rydbeck was developed radio technology in 1989 and after he named as Bluetooth at Ericsson Mobile in Lund Sweden. First Bluetooth was launched in the market in 1999. It is low cost and freely- available in the market. It is used to communicate with short range of devices with the help of bandwidth. Mainly it is used to replace the wired technology into wireless technology to design projects. It has 6 pins. Tx pin is used to transmit the data and Rx pin is used to receive the data and one pin is for ground pin and another pin is for Vcc. Rest two pins are key and state pins. It is connected and work in the range up to 100metres. It has lower power radio waves and also frequency band between 2.400GHZ to 2.483.5 GHZ to communicate with devices. It is also named as 2 slaved Bluetooth module for serial communications

6. BLOCK DIAGRAM

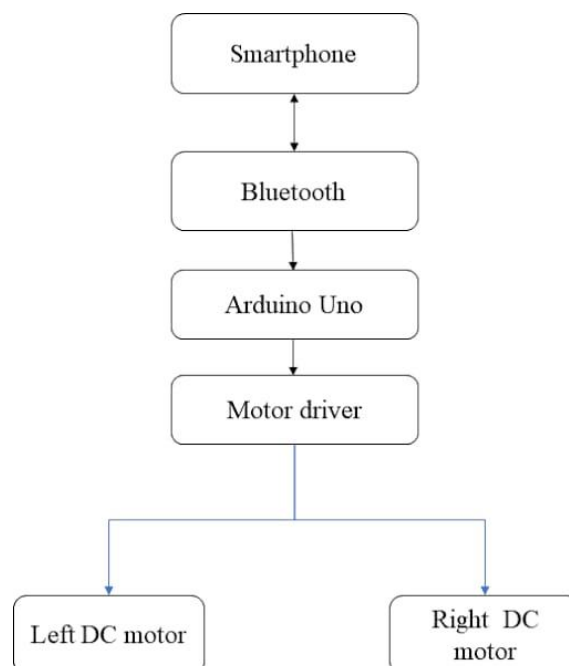

Figure4. Block Diagram

7. RESULTS AND CONCLUSION

First time I designed this model successfully without any struggles in this paper. I kept the connections to the designed model according to the instructions which is given by me successfully. Finally, this designed model can move the several directions and also it can move the robot car from one place to another place. I have tested this designed model many times and many places it performing tasks according to our requirements without any problems. I have designed this model to control user in longdistances with the help of Bluetooth.



8. FUTURE SCOPE

According to my requirement I have designed this model successfully. So, to develop this model there are many problems are there to overcome this issue.

1. I have noticed that while saw the object while moving one place to another place. So, to overcome this issue add the camera is possible in future.
2. 2 nd thing I have noticed that while moving the robot car the range is very low to operate the carin long distance. To overcome the issue updated to the latest version of Bluetooth and increasethe design in future.
3. 3 rd thing I have noticed that while controlling the robot car remotely very tough in some cases. So, adding of Google Assistant is very easy to control in future scope.

9. REFERENCES

- [1] G. Singh, A. K. Singh, A. Yadav, I. Bhardwaj, and U. Chauhan, "IoT developed Wi-Fi Controlled Rover with Robotic Arm Using NodeMCU," Proc. - IEEE 2020 2nd Int. Conf. Adv. Comput. Commun. Control Networking, ICACCCN 2020, pp. 497–501, 2020, doi: 10.1109/ICACCCN51052.2020.9362956.
- [2] H. Durani, M. Sheth, M. Vaghasia, and S. Kotech, "Smart Automated Home Application (Pramanik et al., 2016)using IoT with Blynk App," Proc. Int. Conf. Inven. Commun. Comput. Technol. ICICCT 2018, no. Icicct, pp. 393–397, 2018, doi: 10.1109/ICICCT.2018.8473224.
- [3] S. V. Parvati, K. Thenmozhi, P. Praveenkumar, S. Sathish, and R. Amirtharajan, "IoT Accelerated Wi-Fi Bot controlled via Node MCU," 2018 Int. Conf. Comput. Commun. Informatics, ICCCI 2018, pp. 1–3, 2018, doi: 10.1109/ICCCI.2018.8441215.
- [4] W. M. H. W. Kadir, R. E. Samin, and B. S. K. Ibrahim, "Internet controlled robotic arm," Procedia Eng., vol. 41, pp. 1065–1071, 2012, doi: 10.1016/j.proeng.2012.07.284.
- [5] S. H. Supangkat, InstitutTeknologi Bandung. School of Electrical Engineering and Informatics, and Institute of Electrical and Electronics Engineers., "2018 International Conference on ICT for Smart Society (ICISS) : 'Innovation Toward Smart Society and Society 5.0' : proceeding : Semarang, 10 - 11 October 2018," 2018 Semarang Intl Conf. , no. 2013, pp. 1–5, 2018.
- [6] N. Sobhan and A. S. Shaikat, "Implementation of Pick Place Robotic Arm for Warehouse Products Management," 2021 IEEE 7th Int. Conf. Smart Instrumentation, Meas. Appl. ICSIMA 2021, no. 2015, pp. 156–161, 2021, doi: 10.1109/ICSIMA50015.2021.9526304.
- [7] P. Andhare and S. Rawat, "Pick and place industrial robot controller with computer vision," Proc. - 2nd Int. Conf. Comput. Commun. Control Autom. ICCUBEA 2016, 2017, doi: 10.1109/ICCUBEA.2016.7860048.
- [8] P. Shelke, S. Kulkarni, S. Yelpale, O. Pawar, R. Singh, and K. Deshpande, "A NodeMCU Based Home Automation System," Int. Res. J. Eng. Technol., vol. 9001, pp. 127–129, 2008.
- [9] M. M. Rathore, A. Ahmad, and A. Paul, "The Internet of Things based medical emergency management using Hadoop ecosystem," 2015 IEEE SENSORS - Proc., pp. 1–4, 2015, doi: 10.1109/ICSENS.2015.7370183.