

## IOT BASED SMART ENERGY METER MONITORING WITH THEFT DETECTION

Tamilkumar V<sup>1</sup>, Mariselvam M<sup>2</sup>, Pandi Selvakumar K<sup>3</sup>, Dr. T. S. Arun Samuel<sup>4</sup>

<sup>1,2,3</sup>UG Student ECE, National Engineering College, Kovilpatti, Tamil Nadu, India.

<sup>4</sup>Professor ECE, National Engineering College, Kovilpatti, Tamil Nadu, India.

### ABSTRACT

India is currently experiencing a large-scale electricity crisis. This project introduces an active and reactive power monitoring system based on a Wi-Fi module. Energy data gathering systems are becoming an important aspect of research and development. If any consumers are consuming reactive power, their energy usage behavior can be easily identified, and their bills can be decreased. This paper describes a Wi-Fi-based smart energy meter method for reducing electricity theft and determining reactive power usage in the absence of a customer by connecting a smart energy meter in the office. There are numerous approaches for putting together energy detail usage. The project's main purpose is to begin reducing reactive power consumption by IOT base, microcontroller, and LDR sensors. Single phase induction motors consume reactive power and have a current transformer (CT) that creates a large amount of current. This data, sensor data, is fed into the microcontroller, which then sends it to the Wi-Fi module to let the user know how much power they are using. Finally, on the LCD, display all energy statistics, unit utilization, reactive power, and penalty factor (power factor).

### 1. INTRODUCTION

In today's generation, proper energy utilization is critical. Energy cannot be created or destroyed; instead, it can only be transformed from one form to another. So, the easiest strategy to reduce power waste is to accurately monitor all energy uses. However, energy monitoring cannot be done correctly because the cost paid by a distributor in detecting electricity theft by their customers exceeds the costs of the entire sector. When one of its customers detects power theft, the supplier may bear responsibility for generation, network, and balancing expenses linked with the customer's input into the settlement system with estimations of electricity creep. Electricity theft is a typical means of immediately inspecting for evidence by department personnel and by detecting meters. These methods of measuring power consumption seals can, in fact, be easily broken. However, security can detect flaws in active power meters, and the resolution of electricity uses data accumulated by this smart technology, which will rely on conventional detection techniques. This method has a good chance of improving meter reading, pay scale, and data collecting, as well as determining clever practice and incorrect circuit. The key reason for the theft is not focusing on the customer who stole the electricity and jeopardized all power supply security. The lack of a method, as well as inefficient electrical distribution, are important contributors to this problem.

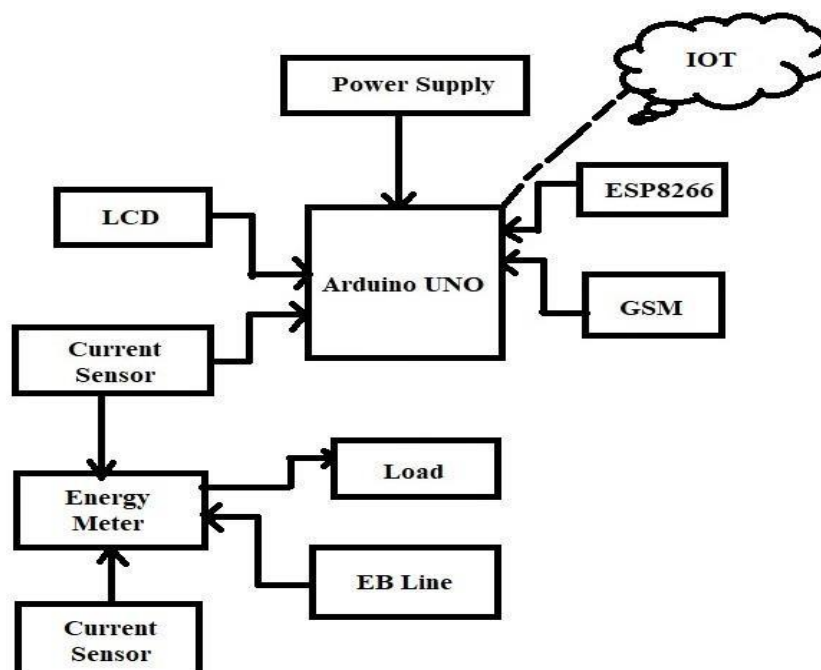

Fig 1 - Block Diagram

## 2. LITERATURE SURVEY

We learned through our research paper that Bharath.D, Dhivya C, and Monisha An IoT-enabled smart energy meter via utilizing Advanced Technologies, researchers attempted to make every system automatic and trustworthy. This paper provides information on strategies for monitoring energy usage via smart energy meter by connecting meters system gives continuous reading through microcontroller. Risa Rasheed, Ajeeba A A, Anna Thomas Meter reading theft detection and disconnection using IoT. In this paper, we provide a microcontroller-based design and implementation of an energy meter that allows users to trace any misbehavior in the system from any location.

## 3. METHODOLOGY

### BLOCK DIAGRAM DESCRIPTION POWER SUPPLY

A power supply converts an alternating current power line's output into a single continuous direct current output or a number of outputs. After being rectified to create pulsing direct current, which is then filtered to provide a smooth voltage, the alternating current voltage is converted to direct current.

### CURRENT SENSOR

A current sensor is a device that detects a gadget that recognizes a measurable output voltage proportionate to the current flowing via the measured route from the measured current. Each type of sensor has been specifically designed for a certain current range and ambient condition.

### IOT CLOUD

The term "IoT cloud" refers to a sizable network that hosts IoT devices and applications. Real-time operations and processing require the underlying infrastructure, servers, and storage that is provided.

### ESP8266

ESP8266 The ESP8266 Wi-Fi Module is an integrated TCP/IP protocol stack-equipped self-contained SOC that enables any microcontroller to connect to your Wi-Fi network..

### ARDUINO UNO

When learning about electronics and programming, the Arduino UNO is a fantastic board. The UNO is the ideal place to start if you've never used the platform before. The most well-known and well-documented Arduino board is the UNO.

### ENERGY METER

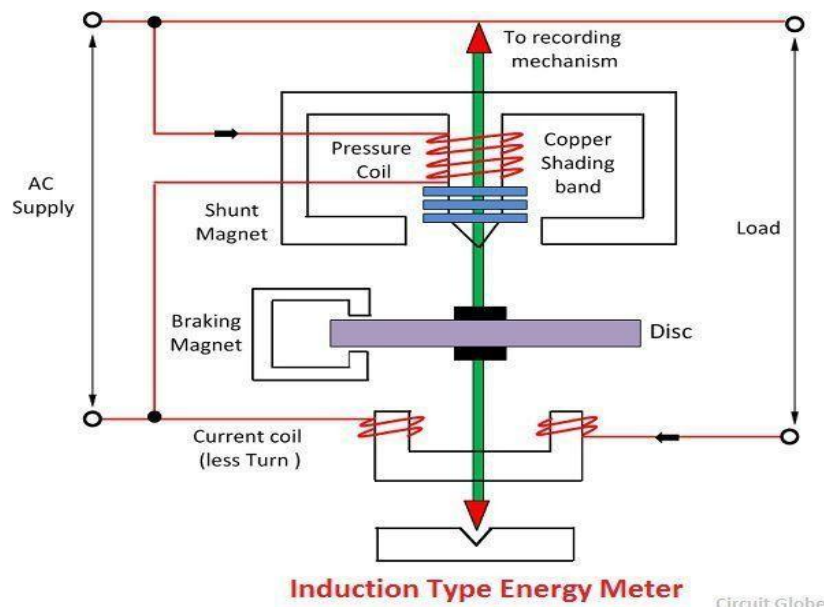

**Figure 2** – Induction type Energy meter

The quantity of energy used by an electric load is measured using an energy meter. Energy is the collective amount of power that the load is using at any given time. Both household and commercial AC circuits use it to keep an eye on power usage. Both the cost and the accuracy of the meter are lower.

technique for reading electricity energy meters. In this design, the IoT concept is employed to implement the energy meter. The Arduino is key to this entire method. The internet of things (IoT) enables data transmission between items. Through IoT, the energy meter is linked to the internet in the aforementioned arrangement. Consequently, users have a means of monitoring their energy usage. This solution is suitable for both customers and providers. This method

eliminates the requirement for human interaction during the uploading of connection and disconnection data, Any theft in the sensor must be reported to the provider immediately.

### Diagram of Power Supply

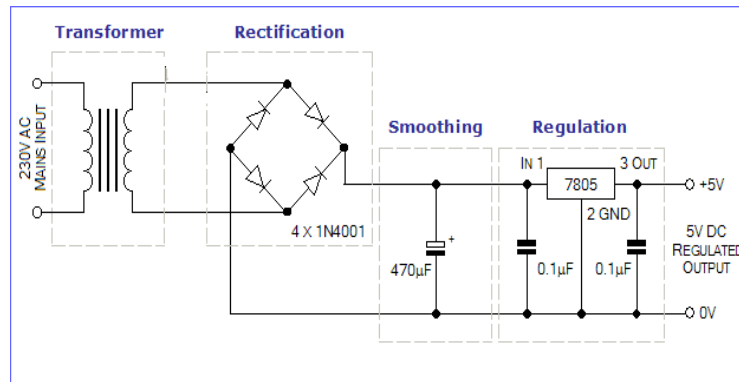

**Figure 3** – Power supply circuit diagram The Provision of electricity units provide the system with a 5v regulated power source. It converts 230 volts alternating current to 5 volts direct current.

### Energy Meter's Operation

A rotating aluminum disc in the energy meter's housing calculates the load's power usage. Between the series and shunt electromagnets' airgaps, the disc is inserted. The current coil is housed in the series magnet, whereas the pressure coil is housed in the shunt magnet. The magnetic field is generated by the pressure coil in response to the supply voltage and the current coil in response to the existing. By using a voltage coil, a magnetic field is 900 behind that produced by the current coil, resulting in eddy current in the disc. Torque is produced by the eddy current's interaction with a force is applied to the disc by the magnetic field. As a result, Rotation of the disc begins.

### WORKING PROCESS

In this study, we explain an IoT-based

#### LCD:

16 characters can be shown on each of the two lines of a 16x2 LCD. This LCD uses a 5x7 pixel matrix to display each character. This LCD comes with both command and data registers. The command register contains the directional commands for the LCD. Requests made to an LCD are known as commands that tells it to do something, such initialize it, clean its screen, set the pointer location, manage the display, etc. Data is stored in the data register that will be displayed on the LCD. For the character that will be displayed on the LCD, the information is an ASCII value. When changing the color of light, liquid crystals (LCs) are used in a liquid crystal

display (LCD), which is a small, flat electronic display. LCs do not emit light directly. Wide- ranging uses for them include signal lights television, instrument panels, cockpit displays for aircraft, and computer and television monitors.

LCD displays have largely taken the role of cathode ray tube (CRT) displays in the majority of applications. They are typically easier to see, lighter, smaller, more portable, affordable, and more reliable.

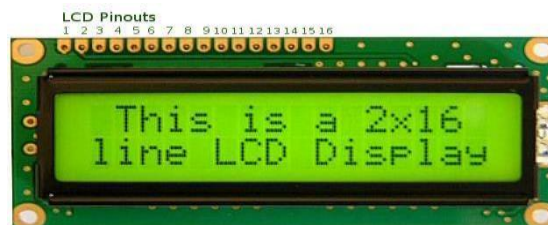

**Figure-4** LCD display

### SOFTWARE DESCRIPTION

On the ATmega328P (datasheet) microcontroller, the Arduino Uno microcontroller board is based. Six analogue inputs, a 16 MHz quartz crystal, a USB port, a power jack, an ICSP header, and a reset button are among its other features. It contains 14 digital I/O pins, six of which are PWM outputs. The only thing left to do is connect it to a computer through USB, power it with an AC-to-DC adapter, or use a battery to get started utilising the microcontroller, which comes with everything you need. Without fear of making a mistake, you can experiment with your UNO; if something goes wrong, you can buy a replacement chip and start over for a few dollars. To commemorate the launch of the Arduino Software (IDE), the name "Uno" which means "one" in Italian was chosen. 1.0. The Arduino software (IDE) and Uno board were the first iterations of the platform; these were later changed. The Arduino Uno board is the first of a series

of USB Arduino boards and acts as the platform's reference model; you can see a complete list of all current, previous, and defunct boards by visiting the Arduino index of boards.



Figure-5 Arduino Uno R3

**Programming-** For Arduino Uno programming, use the Arduino Software (IDE). Depending microcontroller on on the, your board, choose "Arduino/Genuine Uno" under Tools > Board. The reference and tutorial sections contain further details. The boot loader that is preprogrammed inside you can upload fresh code to the Arduino Uno's ATmega328 processor without using an external hardware programmer, thanks to this feature. (See: C header files) The communication protocol is the original STK500 protocol. An Arduino ISP or a similar device's ICSP connector can be used to circumvent the boot loader and reprogram the microcontroller.

The Arduino repository contains the firmware source code for the ATmega16U2 (or 8U2 in therev1 and rev2 boards).

- To raise the 8U2 on Rev1 boards, first solder the jumper to the board's back (near the Italy map).
- A resistor pulls the 8U2/16U2 HWB line to ground on Rev2 and later boards to make it easier to enter DFU mode.

The DFU programmer or FLIP software, respectively, can then be used to load new firmware on Mac OS X and Linux systems. Additionally, a third-party programmer can replace the DFU boot loader with the ISP header. For further details, see this user-contributed tutorial.

#### 4. CONCLUSION

Electricity is one of the most priceless resources. The only way we can utilize the meagre quantity of electricity provided by EB is through our project. As a result, the client is informed of excessive power use via the Power use Alert System. This increases the ability to charge below breaking points and to spar effectively. To increase the precision of capability utilization, a tiny module made up of a Microcontroller, ESP8266, and GSM might be utilized with intelligent energy meters.

#### 5. REFERENCES

- [1] Jacob, R., & Babu, A. (2018). IOT Based Last Meter Smart Grid With Energy Theft Detection. International Journal of Advanced Research Trends in Engineering and Technology (IJARTET), 5, 31-36.
- [2] Hiwale, A. P., Gaikwad, D. S., I 6/11 A., & Mhatre, P. C. (2018). IoT base sma energy monitoring. International Research Journal of Engineering and Technology (IRJET), 5(03).
- [3] Li, W., Logenthiran, T., Phan, V. T., & Woo, W. L. (2019). A novel smart energy theft system (SETS) for IoT-based smart home. IEEE Internet of Things Journal, 6(3), 5531-5539.
- [4] Talwar, P. D., & Kulkarni, S. B. (2016). IoT based energy meter reading. International Journal of Recent Trends in Engineering and Research, 2(6).
- [5] Jain, R., Gupta, S., Mahajan, C., & Chauhan, (2019). Research paper on IOT based smart energy meter monitoring and controlling system. Int. J. Res. Electron. Comput. Eng, 7(2), 1600-1604.
- [6] Aswini, R., & Keerthihaa, V. (2020, July). IoT based smart energy theft detection and monitoring system for smart home. In 2020 International Conference on System, Computation, Automation and Networking (ICSCAN) (pp. 1-6). IEEE.
- [7] Mufassirin, M. M., & Hanees, A. L. (2018). Development of IOT based smart energy meter reading and monitoring system.

- 
- [8] Amudhevali, R., & Sivakumar, T. (2021, February). IoT based smart energy metering system for monitoring the domestic load using PLC and SCADA. In IOP Conference Series: Materials Science and Engineering (Vol. 1055, No. 1, p. 012154). IOP Publishing.
- [9] Gill, T. S., Shehwar, D. E., Memon, H., Khanam, S., Ahmed, A., Shaukat, U., ... & Zaidi, S. S. H. (2021, December). IoT Based SmartPower Quality Monitoring and Electricity Theft Detection System. In 2021 16th International Conference on Emerging Technologies ICET) (pp. 1-4). IEEE.