

PERFORMANCE ANALYSIS OF VARIOUS PRE-EQUALIZATION TECHNIQUES FOR VISIBLE LIGHT COMMUNICATION

R. Priyadharshini¹, A. Sivanantha Raja²

^{1,2}Alagappa Chettiar Government College of Engineering and Technology, Karaikudi – 630003, Tamilnadu, India.

ABSTRACT

Visible Light Communication (VLC) is a well known emerging technology for indoor communication that has drawn more attention in recent years. The name itself indicates that the medium to transfer data in VLC technology is the light that travels in free space. During VLC Inter-Symbol Interference (ISI) in free space channel occurs due to reflectivity of surfaces like walls and ceiling. In order to overcome this problem an inverse filter called equalizer is placed. Equalizers are feasible solution to improve the transmission performance. In this paper, the performance of VLC system is analyzed with various pre-equalization techniques using Optisystem V.16 simulation tool for a practically measured parameters since the spectrum of LED required equalization. This simulation is carried out by placing various equalizers such as Spaced Feed Forward Equalizer, Fractionally Spaced Feed Forward Equalizer, Decision Feedback Equalizer, Combination of both Feed Forward and Decision Feedback Equalizer and Adaptive Equalizer at transmitter side for different bitrates and different link ranges. With adaptive pre-equalization, this VLC system can support 2 Gbps data rate up to 5 m range with a Q factor of 8.52. Under the influence of external white light (noise) of power -80dBm and below, the proposed system works well. Above -80dBm, the modulated light is disturbed, so that the data obtained is slightly degraded.

Keywords: Visible Light Communication (VLC), Post-equalization, White light source, Free Space Optics Channel, Optisystem, Photonics.

1. INTRODUCTION

'Visible Light' is a form of electromagnetic radiation with extremely high frequencies, roughly lies between 400 THz and 800 THz, corresponding to the wavelength range between 780nm and 375nm. Nothing is more faster than light in the Universe as it travels at 3×10^8 m/s in free space. So, undoubtedly the Visible Light Communication (VLC) technology paves way for very high speed transmission of data.

The concept of VLC emerged prior to the invention of radio transmission. It can be considered that the active research on VLC started from 2005 onwards[1]. Light Fidelity (Lifi) technology is the most recently developed VLC technology. The advantages of VLC are unregulated visible spectrum, high bandwidth, high security, harmless to humans, energy saving, robust to electromagnetic interference (EMI) and simple infrastructure requirements[2].

The VLC technology is emerged due to the development and commercialization of light emitting diodes (LEDs) which emits the light in the visible wavelength range, that has been successful for light illumination in recent years. For VLC system, generally the white light emitted from LED is used as source, due to the fact that it is used for both illumination and data transmission and it has huge amount of bandwidth so as to deliver data at higher bitrates [3]. The white light from LED which carries data reaches photodiode by means of free space which is the travelling medium of data. The signal to be transmitted is modulated, in order to make it imperceptible to human eyes in several ways such as intensity, polarization and phase/frequency modulation techniques. Due to simple and easy implementation, intensity modulation is used to transmit data and the intensity detected is converted to electrical signal by means of photo detector called direct detection [4].

A Phosphorescent white LED is created by the use of blue LED coated with a phosphor layer that emits yellow light. A portion of the blue LED's short wavelength light is absorbed by the phosphor layer, and the released light from the absorber subsequently undergoes a wavelength shift into a longer wavelength of yellow light. The necessary white colour is produced by the red-shifted emission's additive mixing with the non-absorbed blue component. However, the modulation bandwidth of the phosphorescent white LEDs is only a few MHz due to the phosphor's delayed reaction. It is necessary to avoid the phosphor coating's bandwidth-limiting effect in order to attain large data rates [5]. High data rates can be attained via a variety of methods. In particular, techniques such as blue filtering at the receiver to remove yellowish components with a delayed response [6], Pre-equalization at the LED driver module, Post-equalization at the receiver [7,8], using all three of the aforementioned methods together and making use of more complicated modulation techniques that allow each transmitted symbol to carry multiple bits have been attempted by contemporary researchers all over the World. Under different modulation techniques, Orthogonal Frequency Division Multiplexing (OFDM) combined with multilevel modulation techniques like Quadrature Amplitude Modulation (QAM) is attempted to achieve high data rate [2].

In this proposed paper, pre-equalization techniques are chosen to attain large data rates and the effectiveness of these techniques is examined with VLC systems. The practically measured parameter values from the earlier research work [3] for White LEDs and Free space channel of 5m X 5m X 3m are used in simulation of VLC system. The transmitted data is detected using positive – intrinsic – negative (p-i-n) photodetector. Spaced Feed Forward Equalizer, Fractionally Spaced Feed Forward Equalizer, Decision Feedback Equalizer, combination of both Feed Forward and Decision Feedback Equalizer and Adaptive Equalizer were placed at transmitter side and the performance of the VLC system is determined by using the Q-factor and Bit Error Rate(BER) values.

This paper is organized as follows. In Section 2, the experimental setup of Pre equalized White LED based VLC system is described. Section 3 discusses the results, and conclusion is given in Section 4.

2. EXPERIMENTAL SETUP

Block diagram of the VLC system is shown in Fig.1 and the experimental setup for the pre-equalized VLC system is shown in Fig.2, which is implemented in Optisystem V.16 software. The Pseudo random bit sequence is generated by pseudo random bit sequence generator which is the input data to the system. This input sequence is intensity modulated by Non-Return to Zero(NRZ) On-Off Keying(OOK) modulation. The modulated input sequence is then fed to an equalizer that equalizes the white light spectrum, while transmitting data via white LED. In order to update the tap weight coefficients, it is necessary to feed the equalizer with a training sequence, which is the input sequence itself or optical null or any OOK modulated signal. This system arrangement is analyzed by placing various equalizers such as Spaced Feed Forward Equalizer, Fractionally Spaced Feed Forward Equalizer, Decision Feedback Equalizer, combination of both Feed Forward and Decision Feedback Equalizer and Adaptive Equalizer at the transmitter side. The light from white LED sends data through free space channel. Table 1 & 2 gives the practically measured white light source and FSO channel parameters.

$$S = \eta\lambda/1240 \quad (1)$$

Where, S is Responsivity in A/W, η is Quantum efficiency of source and λ is wavelength in nm.

Then the signal is received by PIN photodetector that converts optical signal to electrical signal, whose responsivity is calculated by using equation (1). The signal is further filtered by low pass Bessel filter for output performance analysis. By using BER analyzer, the values of Q-factor and BER for various link ranges and bit rates are analyzed and the performance of a Visible Light Communication system is studied. The performance of these systems are also analyzed under the influence of external white light or noise as shown in Fig.3.

Table 1 : White light source parameters for 5 X 5 X 3 m3 Room

Wavelength	550nm
Electron life time	100ps
RC constant	100ps
Quantum efficiency	0.65
Bandwidth	300 nm

Table 2 : FSO channel parameters

Attenuation (for free space)	8dB/m
Transmitter aperture diameter	7 cm
Receiver aperture diameter	1.5 cm
Beam divergence	1108.284mrad = 63.5 degree

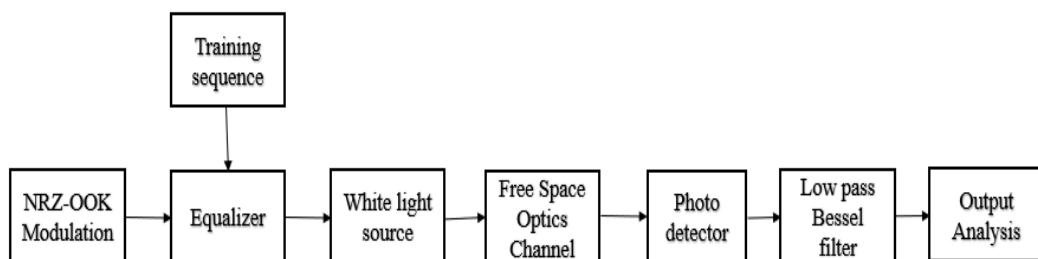

Fig 1 : Block diagram for the pre equalized VLC system

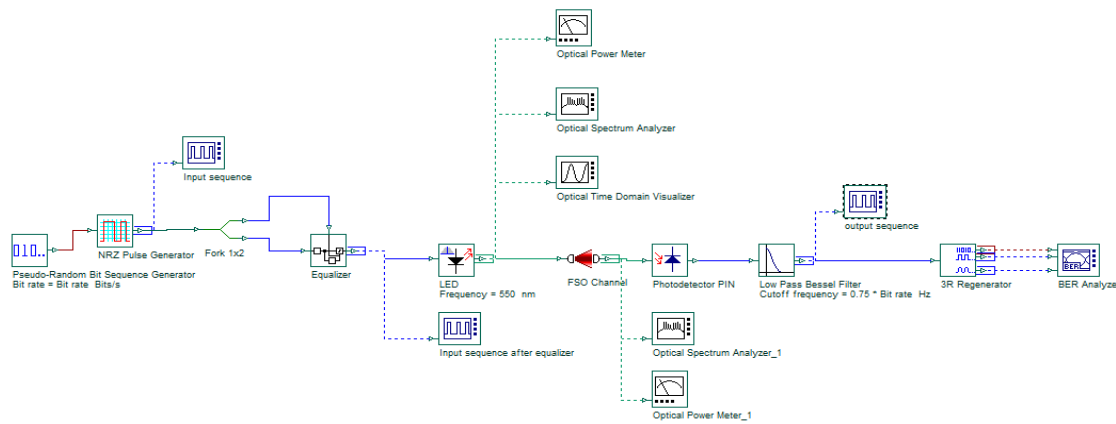

Fig 2 : Experimental setup for the Pre-equalized VLC system in Optisystem V.16 software

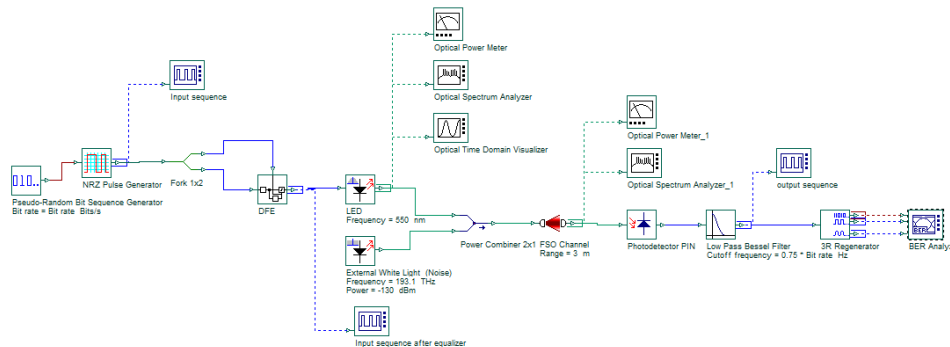

Fig 3 : Experimental setup for the Pre-equalized VLC system in Optisystem V.16 software with external white light influence

3. RESULT AND DISCUSSION

3.1 Feed Forward Equalizer (FFE)

It is a symbol-spaced finite-impulse response (FIR) filter to a sample-by-sample input signal. This equalizer reduces distortions due to channel loss impairments. The parameter “forward taps space” defines the tap spaces.

Based on value of Forward tap space the FFE is divided into two types,

- Spaced FFE (Forward taps space is equal to 1)
- Fractionally spaced FFE (Forward taps space is greater than one)

Fig 4 and 5 represent the results of spaced FFE and Fractionally spaced FFE. Both systems have an ability to transmit 1 Gbps data upto 4m without external white light noise influence. Under the noise influence it transmits 1 Gbps data upto 3m or less.

3.2 Decision Feedback Equalizer (DFE)

It is a form of non-linear equalization which relies on decisions about the levels of previous symbols (high/low) to correct the current symbol. This equalizer needs feed forward and feedback coefficients. The LMS algorithm is used to update the tap weights. Error is determined by factors like "decision instant" and "threshold value".

There are four DFE schemes in this equalization technique, based on the volterra model and a linear FIR model [9].

Fig 6 represent the results of DFE. These systems are able to transmit 1 Gbps data upto 5m without external white light noise influence. Under noise influence it transmits 1 Gbps data upto 4m or less. There is no much difference in the performance of four schemes of DFE.

Table 3 : DFE Schemes

Forward path	Feedback path	Referred as	Initial coefficients
FIR linear	FIR linear	FF	[1,0,0,0] & [1,0,0,0]
FIR linear	3rd order Volterra	FV	[1,0,0,0] & zeros(1,44)
3rd order Volterra	FIR linear	VF	[1, zeros(1,43)] & [0,0,0,0]
3rd order Volterra	3rd order Volterra	VV	[1, zeros(1,43)] & zeros(1,44)

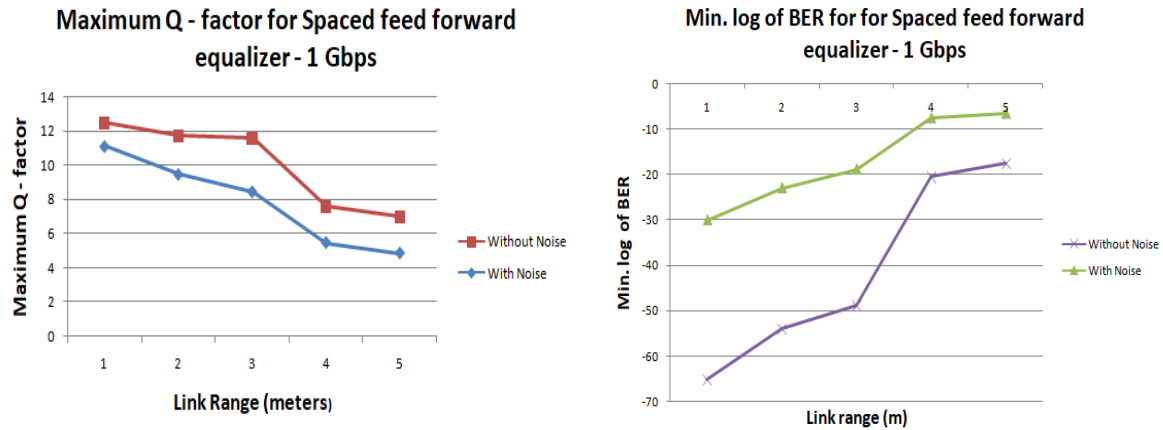

Fig 4 : Simulation results for Spaced Feed Forward Equalizer in pre-equalized VLC system

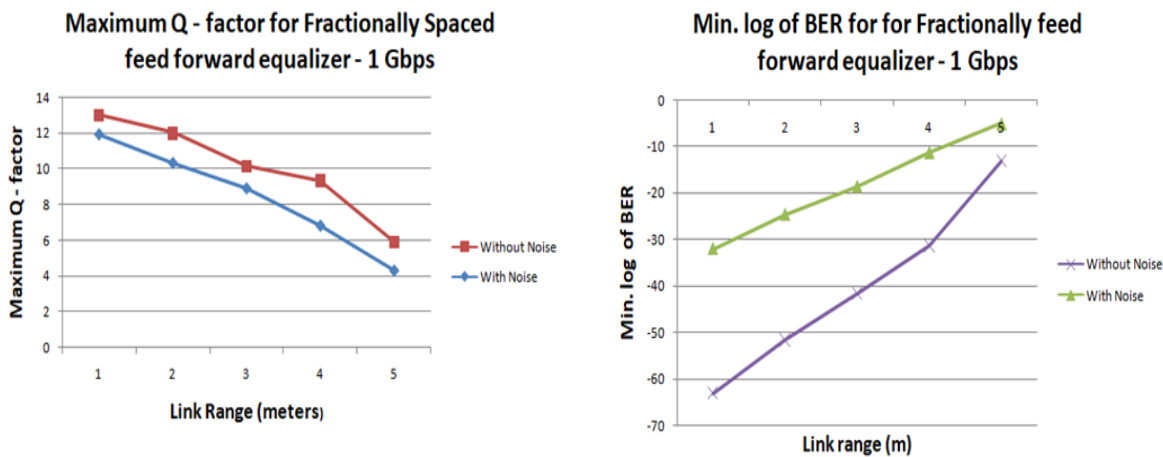

Fig 5 : Simulation results for Fractionally Feed Forward Equalizer in pre-equalized VLC system

3.3 Combination of DFE and FFE

The FFE is linear filter which compensates linear distortion. The DFE is a nonlinear filter which eliminates post-cursors of distorted signals. The combination of DFE and FFE takes advantages of the two equalizers and has better performance.

Fig 7 represent the results of DFE and FFE combination. This system shows improved performance than individual performance of FFE and DFE.

3.4 Adaptive equalizer

An adaptive equalizer compensates for an unknown and time-varying channel, hence it requires a specific algorithm to update the equalizer coefficients and track the channel variations [10]. In Least Mean Square (LMS) algorithm, to prevent the adaptation from becoming unstable, the value of stepsize (α) is chosen from equation (2) [10],

$$0 < \alpha < 2 / \sum_{i=1}^N \lambda_i \quad (2)$$

Fig 8 represent the results of adaptive equalizer. This system transmits 2 Gbps data upto 5m, with a better Q-factor.

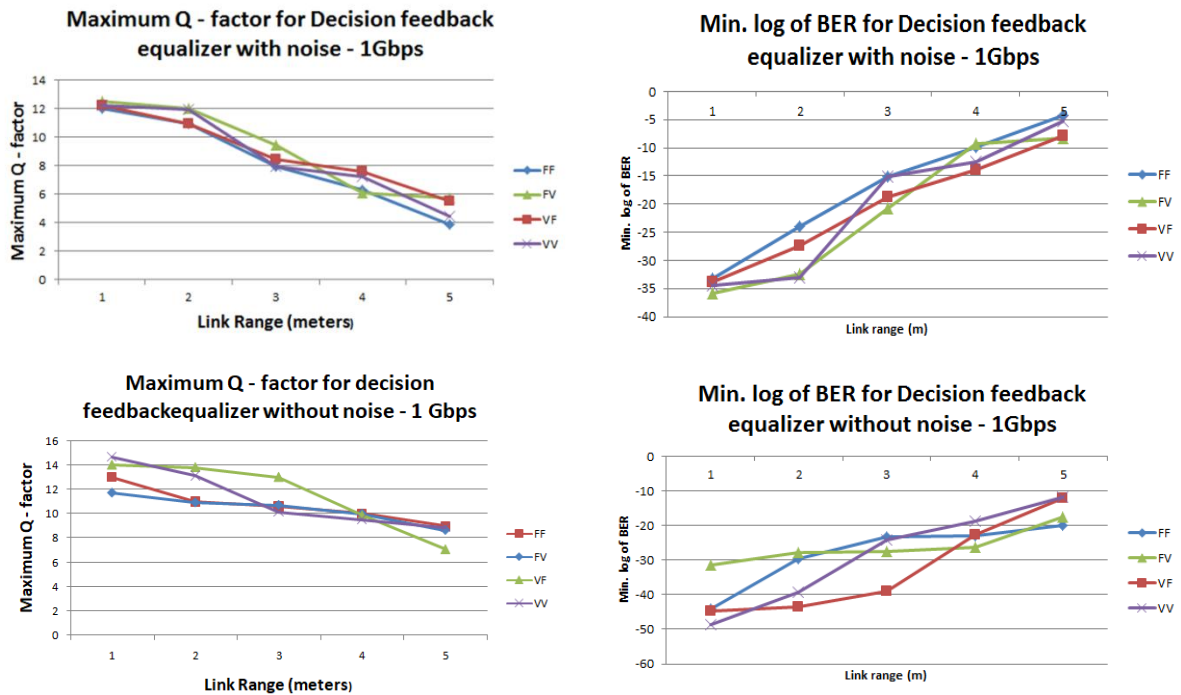

Fig 6 : Simulation results of all the four schemes of decision feedback equalizer in pre-equalized VLC system

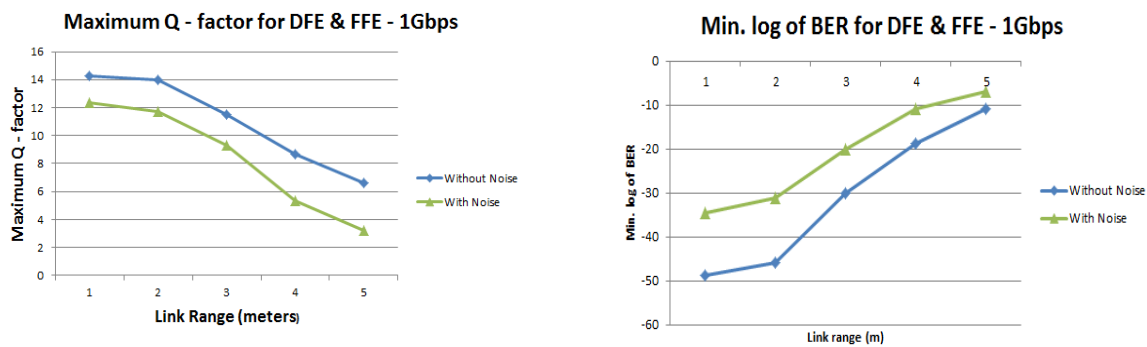

Fig 7 : Simulation results of Combination of DFE and FFE in pre-equalized VLC system

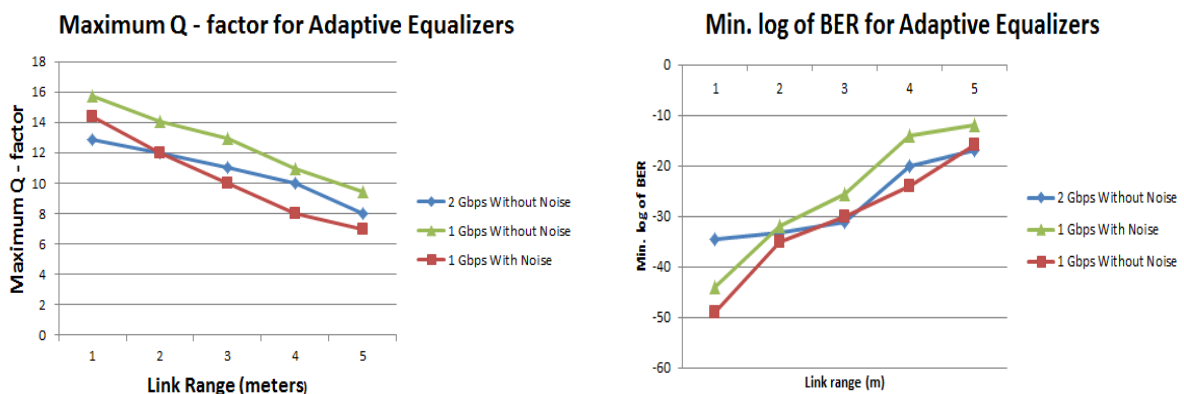

Fig 8 : Simulation results of Adaptive equalizer in pre-equalized VLC system

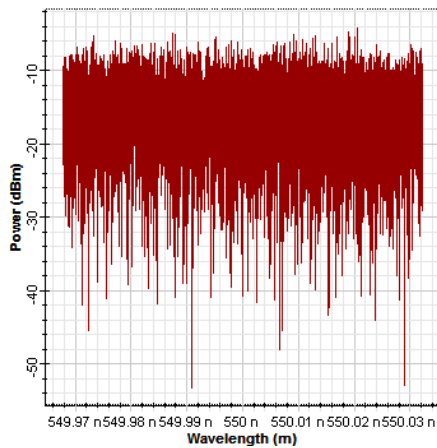

Fig 9 : White light spectrum for center frequency 550nm in Optical Spectrum Analyzer

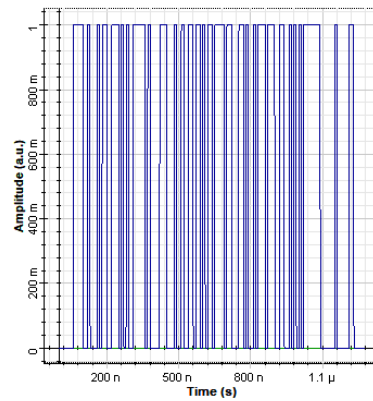

Fig 10 : NRZ-OOK modulated input sequence

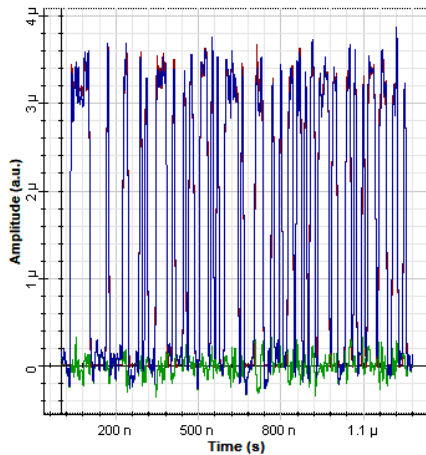

Fig 11 : VLC system output without equalization for 5m :- Blue signals are input sequence and green signals are noise

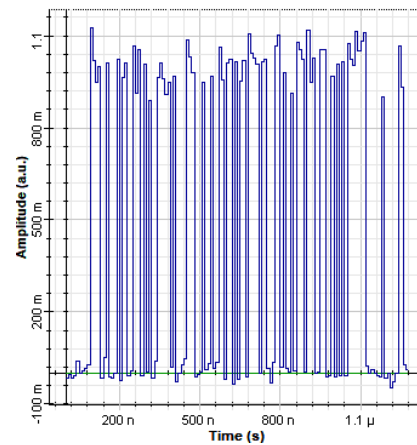

Fig 12 : VLC system after adaptive pre-equalization for 5m :- Signal is equalized and noises are much reduced

Fig 9 shows the white light spectrum at center wavelength of 550nm. Fig 10, 11 & 12 shows the given input sequence, corresponding output with and without equalization respectively.

4. CONCLUSION

In this paper, the analysis of various pre-equalization techniques for Visible Light Communication system is performed. Utilizing practically obtained white LED and FSO channel parameters, the system is modelled using Optisystem V.16 software. The Adaptive Equalizer performs admirably in enhancing the effectiveness of data transmission in the VLC system after analysing various equalizers, including Spaced Feed Forward Equalizer, Fractionally Spaced Feed Forward Equalizer, Decision Feedback Equalizer, Combination of Both Feed Forward and Decision Feedback Equalizer, and Adaptive Equalizer. The adaptive equalizer transmits data at 2Gb/s rate up to 5m and has an 8.52 Q-factor. The proposed system operates well even if it is exposed to external white light (noise) with a power of -80dBm or less. Above -80dBm, the modulated light is distorted, which degrades the input data.

The analysis and simulations reported here support the idea that the suggested system is very promising for future Li-fi and VLC systems. This system can be further improved by MIMO technology which can increase data speed, link range and data throughput without using more power or bandwidth.

5. REFERENCES

- [1] Chung Ghiu Lee (2011). Visible Light Communication, Advanced Trends in Wireless Communications, Dr. MutamedKhatib (Ed.), ISBN: 978-953-307-183-1.
- [2] Selvendran, S., Sivanantha Raja, A., Esakki Muthu, K. & Lakshmi, A. (2019). "Certain Investigation on Visible Light Communication with OFDM Modulated White LED Using Optisystem Simulation". Wireless Personal Communications, 109(2):1377–1394. doi: 10.1007/s11277-019-06617-2

- [3] Manivannan, K., Sivanantha Raja, A. & Selvendran, S (2016). "Performance investigation of visible light communication system using optisystem simulation tool". International Journal of Microwave and Optical Technology, 11(5):377–383.
- [4] K. Sindhubala and B. Vijayalakshmi, "Design and performance analysis of visible light communication system through simulation," 2015 International Conference on Computing and Communications Technologies (ICCCT), 2015, pp. 215-220, doi: 10.1109/ICCCT2.2015.7292748.
- [5] Ghassemlooy, Z., Popoola, W., & Rajbhandari, S. (2018). Optical Wireless Communications: System and Channel Modelling with MATLAB®, Second Edition (2nd ed).
- [6] E. Setiawan, T. Adiono, I. N. O. Osahon and W. O. Popoola, "Experimental Demonstration of Visible Light Communication using White LED, Blue Filter and SoC based Test-Bed," 2019 International Symposium on Electronics and Smart Devices (ISESD), Badung, Indonesia, 2019, pp. 1-4, doi: 10.1109/ISESD.2019.8909625.
- [7] Zhou, Y., "Comparison of nonlinear equalizers for high-speed visible light communication utilizing silicon substrate phosphorescent white LED", Optics Express, vol. 28, no. 2, p. 2302, 2020. doi:10.1364/OE.383775.
- [8] Lubin Zeng et al., "Equalisation for high-speed Visible Light Communications using white-LEDs," 2008 6th International Symposium on Communication Systems, Networks and Digital Signal Processing, Graz, 2008, pp. 170-173, doi: 10.1109/CSNDSP.2008.4610760.
- [9] Han, Xiaoqi & Cheng, Chi-Hao. (2014). Nonlinear filter based Decision Feedback Equalizer for optical communication systems. Optics express. 22. 8712-9. 10.1364/OE.22.008712.
- [10] Rappaport, Theodore Ted S.. "Wireless communications - principles and practice." (1996).
- [11] Goldsmith, A. (2005). Wireless Communications. Cambridge: Cambridge University Press. doi:10.1017/CBO9780511841224
- [12] S. Mohapatra, G. Satapathy, S. P. Dash and P. R. Sahu, "Performance Analysis of Visible Light Communication System With Imperfect CSI," in IEEE Communications Letters, vol. 24, no. 12, pp. 2844-2848, Dec. 2020, doi: 10.1109/LCOMM.2020.3016044.
- [13] Meena, Shiv Ram & Masih, Asbah. (2020). Performance Analysis of Equalizers as Dispersion Compensation for Optical Communication Networks. Gedrag en Organisatie. 33. 405-426. 10.37896/GOR33.03/437.
- [14] A. Anusree and R. K. Jeyachitra, "Performance analysis of a MIMO VLC (Visible Light Communication) using different equalizers," 2016 International Conference on Wireless Communications, Signal Processing and Networking (WiSPNET), Chennai, India, 2016, pp. 43-46, doi: 10.1109/WiSPNET.2016.7566085.
- [15] B. Prasad, B. Mallick, K. C. Patra and N. K. Barpanda, "Dsp based chromatic dispersion equalization techniques in PDM-QPSK receivers," 2019 3rd International Conference on Trends in Electronics and Informatics (ICOEI), Tirunelveli, India, 2019, pp. 302-307, doi: 10.1109/ICOEI.2019.8862630.
- [16] Martinek, R.; Danys, L.; Jaros, R. Adaptive Software Defined Equalization Techniques for Indoor Visible Light Communication. Sensors 2020, 20, 1618. <https://doi.org/10.3390/s20061618>
- [17] T. Komine, J. H. Lee, S. Haruyama and M. Nakagawa, "Adaptive equalization system for visible light wireless communication utilizing multiple white LED lighting equipment," in IEEE Transactions on Wireless Communications, vol. 8, no. 6, pp. 2892-2900, June 2009, doi: 10.1109/TWC.2009.060258.
- [18] Li H, Chen X, Guo J, Chen H. "A 550 Mbit/s real-time visible light communication system based on phosphorescent white light LED for practical high-speed low-complexity application". Opt Express. 2014 Nov 3;22(22):27203-13. doi: 10.1364/OE.22.027203. PMID: 25401871.
- [19] Manivannan, K, Sivanantha raja, A., & Selvendran, S., (2015). Channel Characterization for Visible Light Communication with the Help of MATLAB. International Journal of Advanced Research in Computer Science and Software Engineering (IJARCSSE),. 5. 155-159.